

DATE:

PROJECT:

COMMENTS:

FEATURES

- Approved for use in Class I Div 2, Groups A-D. Class II Div 1 and 2, Groups E-G: T Coded T4A, 73B, T3A, T2D, T2A or T1.
- NEMA 4X and IP66 rated for use in wet and damp applications.
- Designed to stand up to abuse in applications such as schools, institutions, public areas, and apartment complexes where vandalism may occur.
- Conduit fitting approved for hazardous environments.
- Fully adjustable MR16 lamps with LED options.
- Magnetic test switch is used for manual testing - magnet is included.
- Self-Test/Self-Diagnostic monitoring is available.
- Low voltage cut-off prevents battery damage and ensures positive charge acceptance following an extended discharge.
- Uses maintenance free sealed lead calcium or nickel cadmium battery for 90 minute emergency run time.
- Line latch prevents unnecessary discharge of battery during installation. Loads will not illuminate until after application of utility power.
- Short circuit battery protection.
- Brownout detection ensures emergency operation during periods of low line voltage.
- 120/277 VAC with field selectable inputs



ORDERING INFORMATION *HZZ-LC-12V36W-MBC-L125*

1. SERIES

HZZ

2. BATTERY TYPE

LC Lead Calcium Battery Backup

NC Ni-Cad Battery Backup

3. OPERATION

6V18W 6 Volts, 18 Watts
6V36W 6 Volts, 36 Watts
6V60W 6 Volts, 60 Watts

6V22W 6 Volts, 22 Watts
6V42W 6 Volts, 42 Watts

12V36W 12 Volts, 36 Watts
12V60W 12 Volts, 60 Watts

6V54W 6 Volts, 54 Watts
12V42W 12 Volts, 42 Watts

4. MOUNTING

MBC

MBC Back/Ceiling Mount

5. LAMP SOURCE

See Lamp Chart for Part #
 Example: LED Two Head
 12V 5W = "L125"

6. OPTIONS

BLANK = NO OPTION

AA Audible Alarm (Buzzer)

FA Fire Alarm Interface

T1 Time Delay - 120 VAC (15 min.)

T2 Time Delay - 277 VAC (15 min.)

ACCESSORIES; ORDER SEPARATELY

- WG-20.0LX19.0WX9.0D** = Wireguard, Length: 20", Width: 19", Depth: 9"
- WG-26.0LX19.0WX9.0D** = Wireguard, Length: 26", Width: 19", Depth: 9"

SPECIFICATIONS
CONSTRUCTION

- Fully gasketed, die-cast aluminum housing with impact resistant polycarbonate lens
- Stainless steel mounting feet and hardware allows for large gauge wire
- Industrial gray color standard

TEMPERATURE RATING

- From 50°F to 104°F

APPROVALS

- CSA-US Listed
- NEMA 4X
- Class I Div 2 Groups A-D
- Class II Div 1 & 2 Groups E-G
- IP66
- Sanitation Listed
- ETL Verified Splash Zone Listing equal to NSF Standard 2
- Meets or exceeds UL 924 standards
- NFPA 101 Life Safety Code
- NFPA 70-NEC
- OSHA
- BAA Compliant

WARRANTY

Isolite offers a 3-year limited warranty. For further details, refer to General Warranty and Obligations in the Isolite manual or on our website. Lamps not warranted.

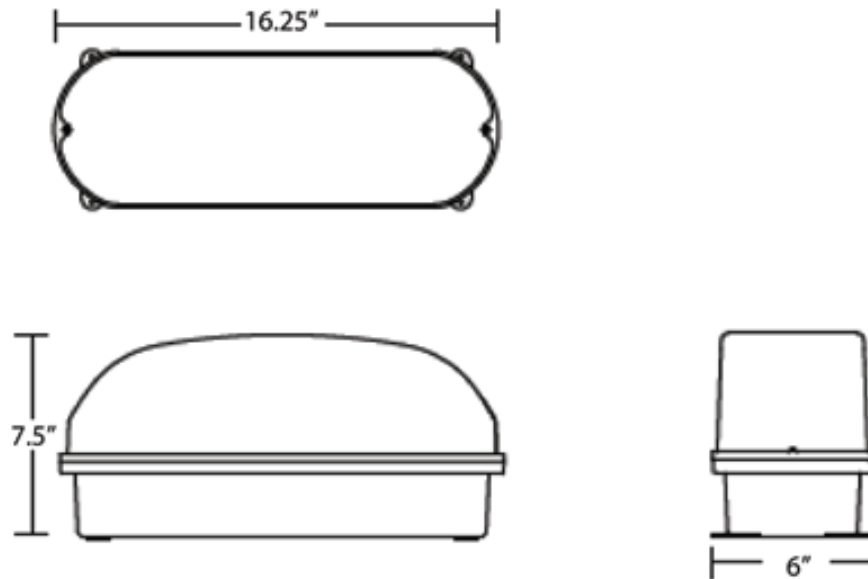
DIMENSIONS

LAMP CHARTS

L - LED		
	6V	12V
2W		L122
5W	L65	L125
7W	L67	L127

LAMP SPACING

UNIT SPACING - 9 FT MOUNTING HEIGHT	
LAMP WATTAGE	SPACING (MULTIPLE UNITS)
2W	50'
5W	60'
7W	100'