



isolite

The Emergency Lighting Experts

INVERTER SIZES & CABINET CONFIGURATIONS

2024

INVERTER SIZES

**Click the size of the product you wish to view*



E3MAC INVERTER SYSTEM

SINGLE PHASE	<i>Page</i>	THREE PHASE	<i>Page</i>
1.0 kVA	3-4	3.0 kVA	28-30
1.6 kVA	5-6	4.0 kVA	31-33
2.2 kVA	7-8	5.0 kVA	34-36
2.8 kVA	9-10	6.0 kVA	37-39
3.0 kVA	11-12	8.0 kVA	40-42
4.0 kVA	13-14	10.0 kVA	43-45
5.0 kVA	15-16	12.5 kVA	46-48
6.0 kVA	17-18	15.0 kVA	49-51
8.0 kVA	19-21	18.0 kVA	52-54
10.0 kVA	22-24		
12.5 kVA	25-27		



E3MAX MODULAR INVERTER SYSTEM

SINGLE PHASE	<i>Page</i>	THREE PHASE	<i>Page</i>
13.3 kVA	55-56	8.5 kVA	59-60
17.0 kVA	57-58	10.5 kVA	61-62
		13.3 kVA	63-64
		17.0 kVA	65-66
		20.5 kVA	67-68
		26.5 kVA	69-70
		33.0 kVA	71-72

E3MAC-1000-1P

1,000-12,500 VA Single Phase Modular AC Inverter

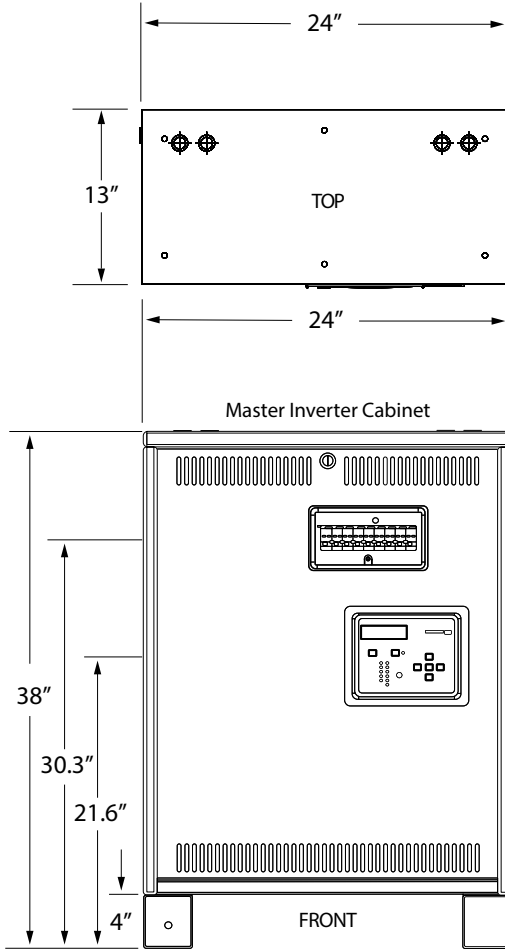

[VIEW SPEC SHEET](#)

WEIGHT					
# of Cabinets	Inverter Cabinet Weight (lbs)	Battery Cabinet Weight (lbs)	# of Batteries	# of Pallets	Total Weight
1	308		4	1	343

E3MAC-1000-1P

1,000-12,500 VA Single Phase Modular AC Inverter

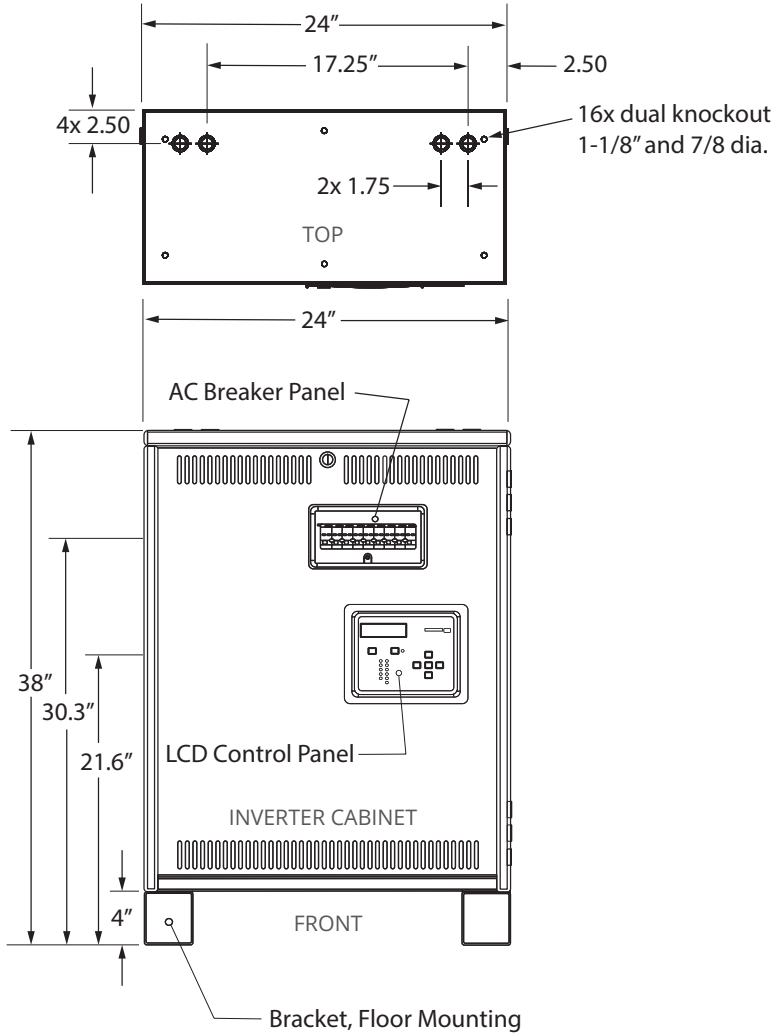



E3MAC-1600-1P

1,000-12,500 VA Single Phase Modular AC Inverter

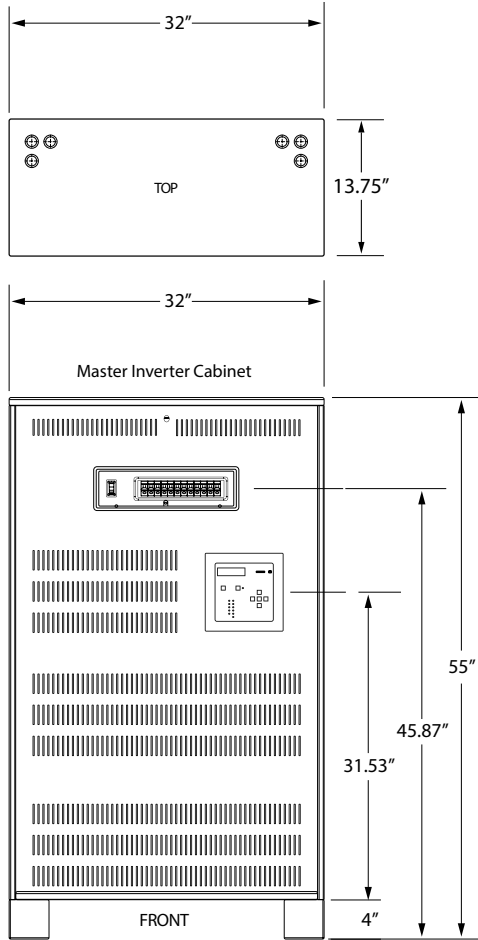

[VIEW SPEC SHEET](#)

WEIGHT					
# of Cabinets	Inverter Cabinet Weight (lbs)	Battery Cabinet Weight (lbs)	# of Batteries	# of Pallets	Total Weight
1	414		6	1	549

E3MAC-1600-1P

1,000-12,500 VA Single Phase Modular AC Inverter

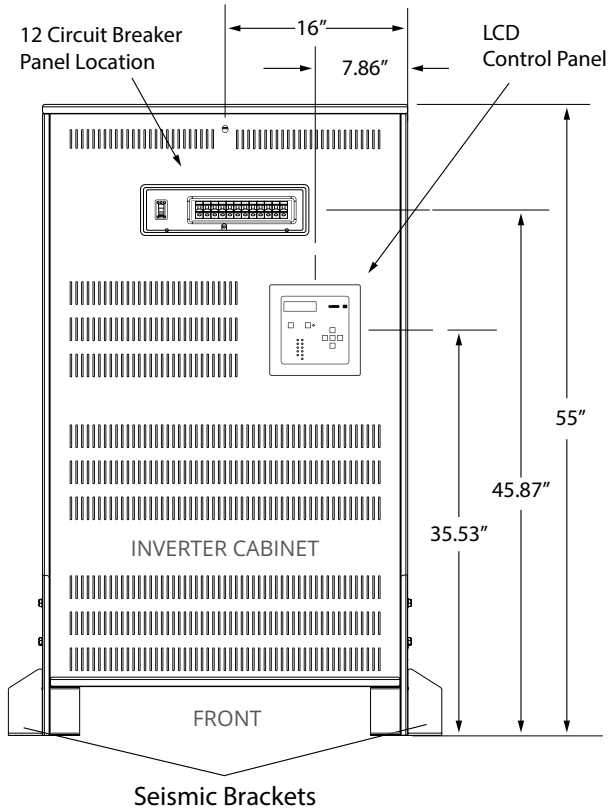
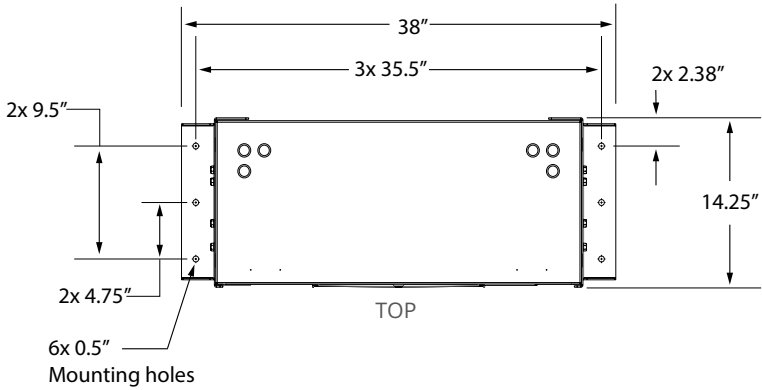



E3MAC-2200-1P

1,000-12,500 VA Single Phase Modular AC Inverter

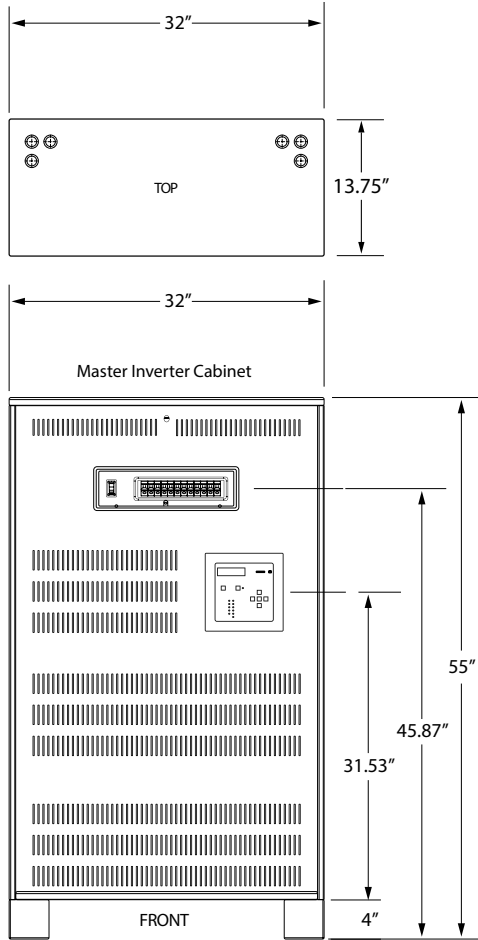

[VIEW SPEC SHEET](#)

WEIGHT					
# of Cabinets	Inverter Cabinet Weight (lbs)	Battery Cabinet Weight (lbs)	# of Batteries	# of Pallets	Total Weight
1	492		8	1	627

E3MAC-2200-1P

1,000-12,500 VA Single Phase Modular AC Inverter

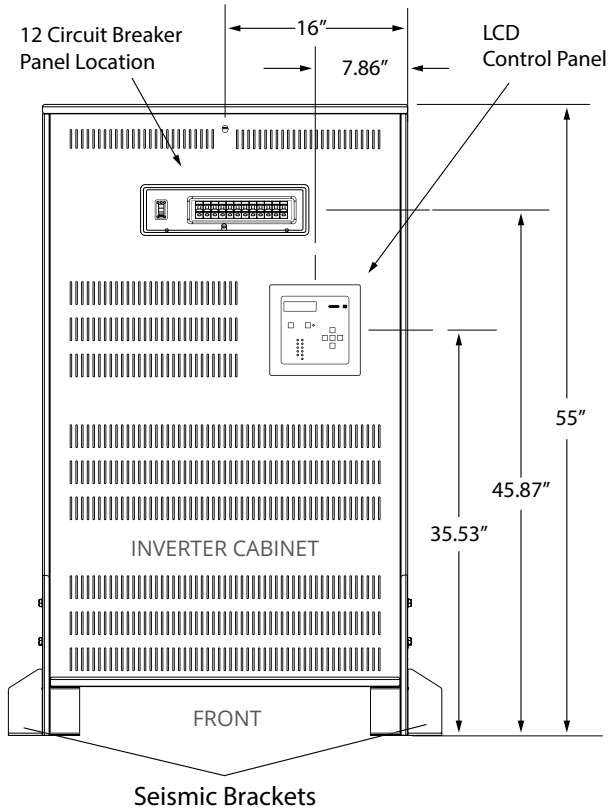
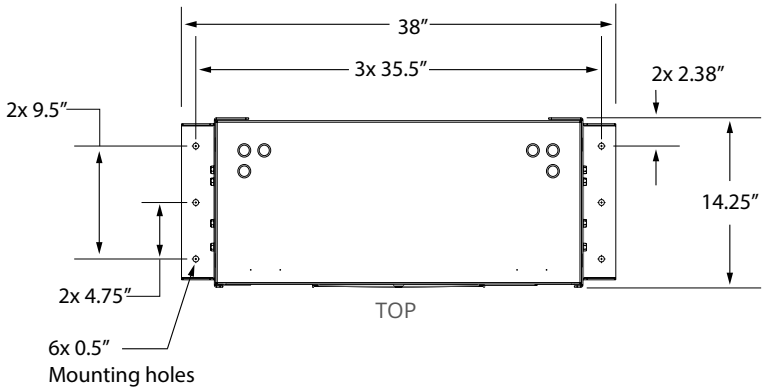



E3MAC-2800-1P

1,000-12,500 VA Single Phase Modular AC Inverter

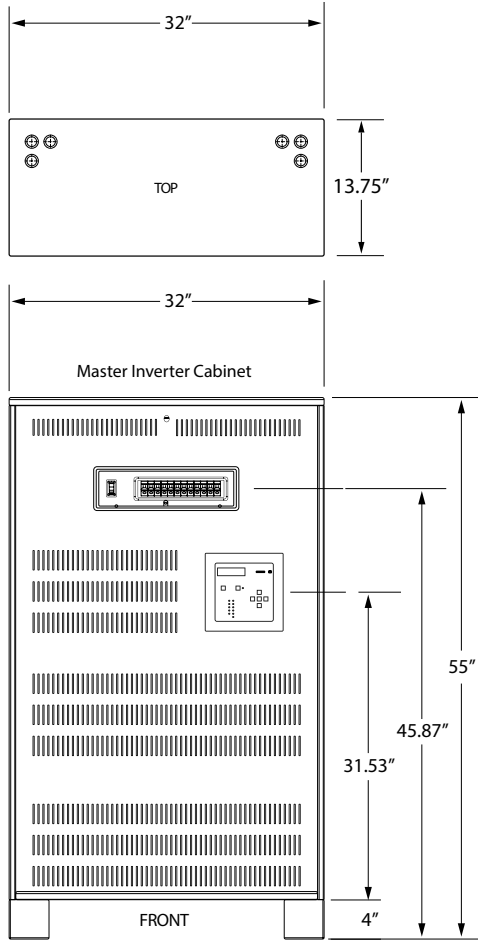

[VIEW SPEC SHEET](#)

WEIGHT					
# of Cabinets	Inverter Cabinet Weight (lbs)	Battery Cabinet Weight (lbs)	# of Batteries	# of Pallets	Total Weight
1	570		10	1	705

E3MAC-2800-1P

1,000-12,500 VA Single Phase Modular AC Inverter

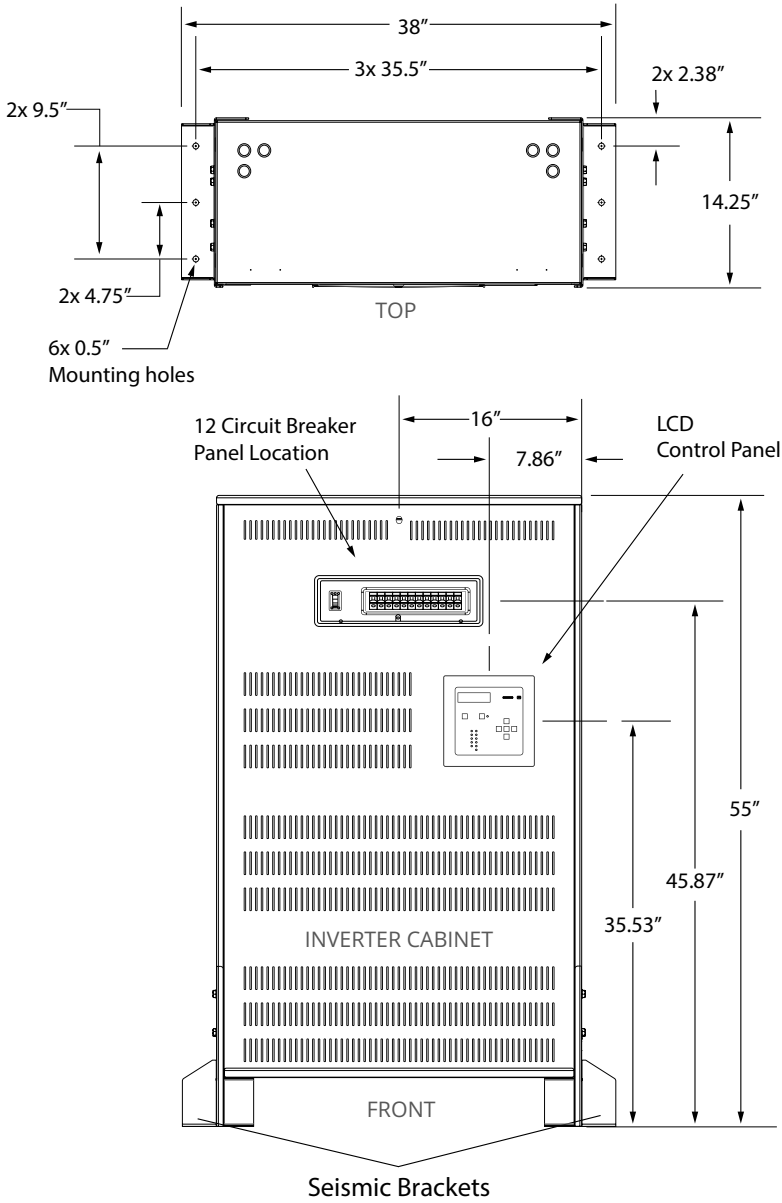

VIEW SPEC SHEET



E3MAC-3000-1P

1,000-12,500 VA Single Phase Modular AC Inverter

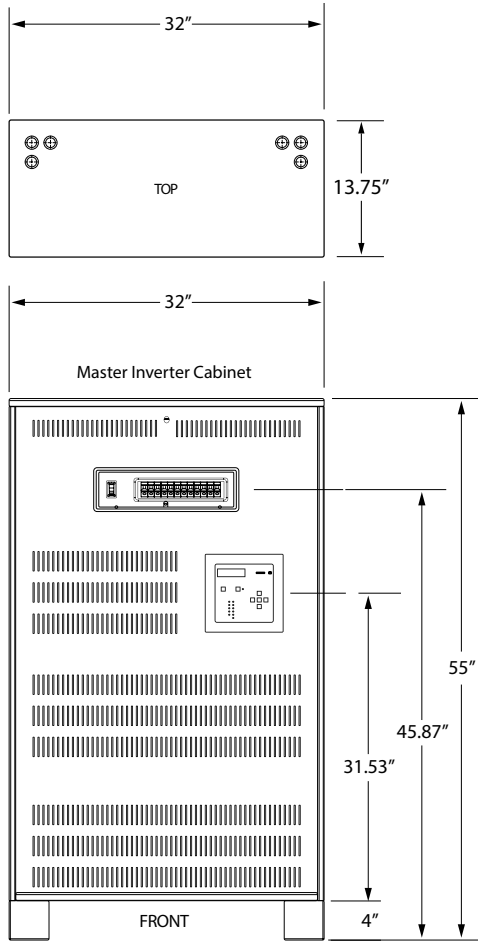

[VIEW SPEC SHEET](#)

WEIGHT					
# of Cabinets	Inverter Cabinet Weight (lbs)	Battery Cabinet Weight (lbs)	# of Batteries	# of Pallets	Total Weight
1	648		12	1	783

E3MAC-3000-1P

1,000-12,500 VA Single Phase Modular AC Inverter

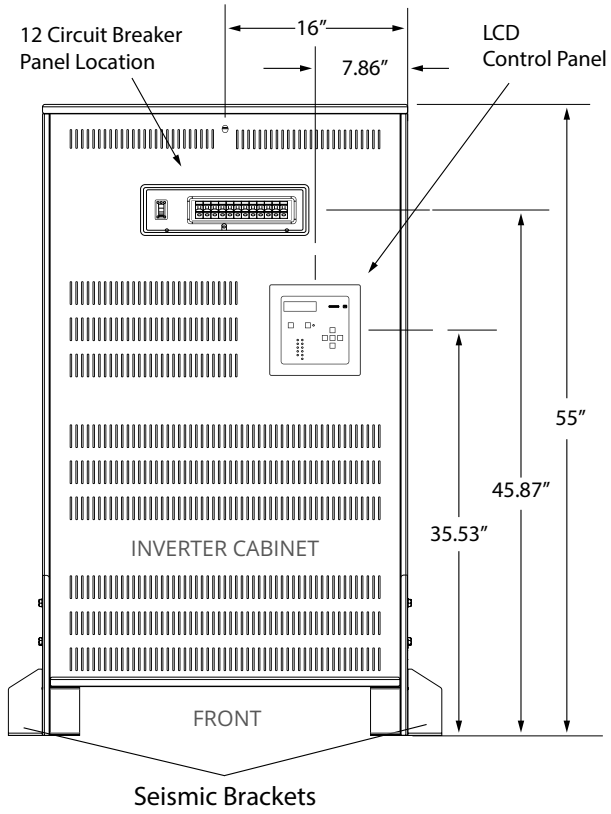
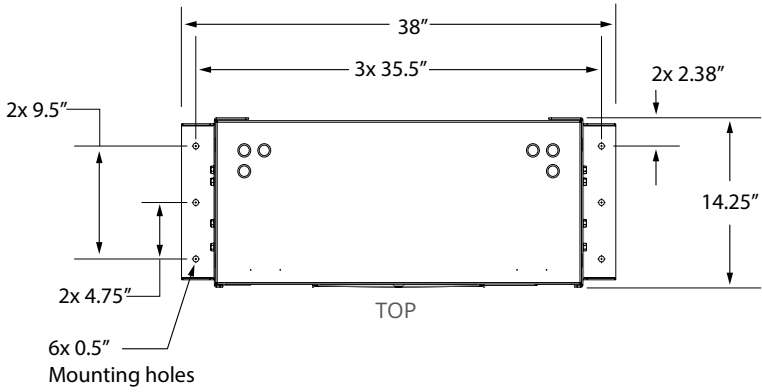

E3MAC-4000-1P

1,000-12,500 VA Single Phase Modular AC Inverter

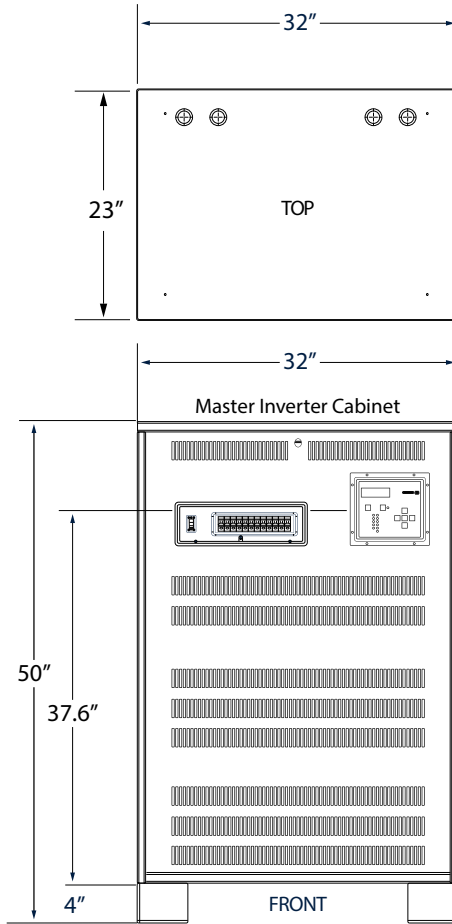

[VIEW SPEC SHEET](#)

WEIGHT					
# of Cabinets	Inverter Cabinet Weight (lbs)	Battery Cabinet Weight (lbs)	# of Batteries	# of Pallets	Total Weight
1	995		8	2	1060

E3MAC-4000-1P

1,000-12,500 VA Single Phase Modular AC Inverter

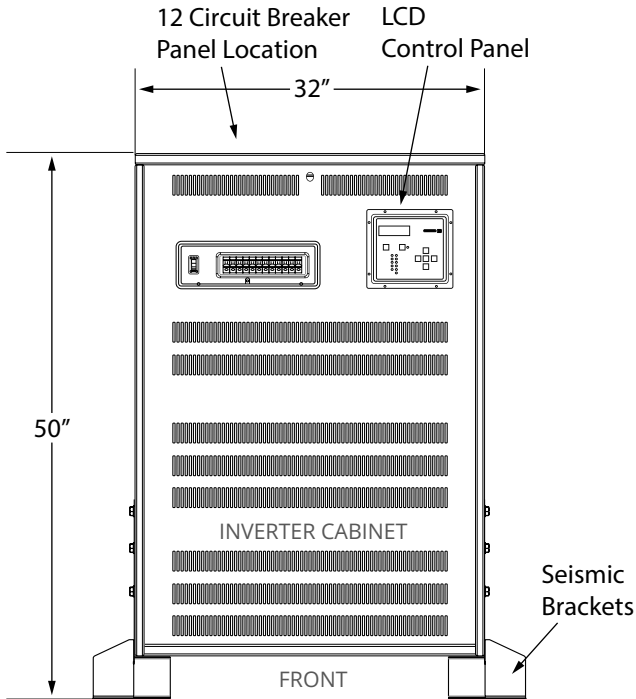
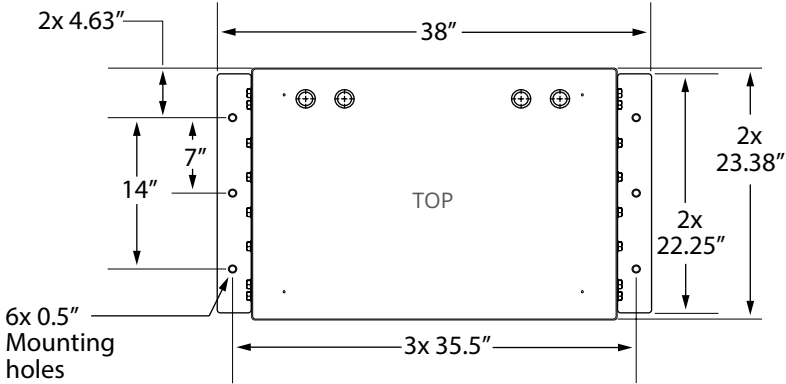



E3MAC-5000-1P

1,000-12,500 VA Single Phase Modular AC Inverter

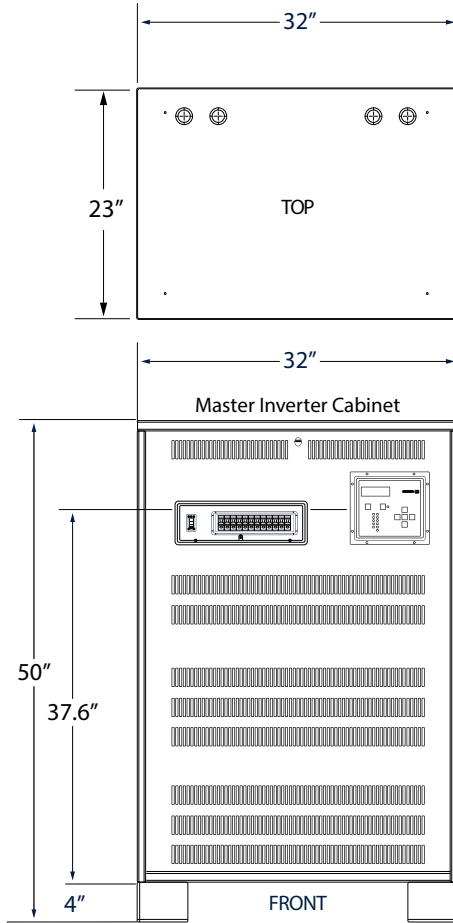

[VIEW SPEC SHEET](#)

WEIGHT					
# of Cabinets	Inverter Cabinet Weight (lbs)	Battery Cabinet Weight (lbs)	# of Batteries	# of Pallets	Total Weight
1	1155		10	2	1220

E3MAC-5000-1P

1,000-12,500 VA Single Phase Modular AC Inverter

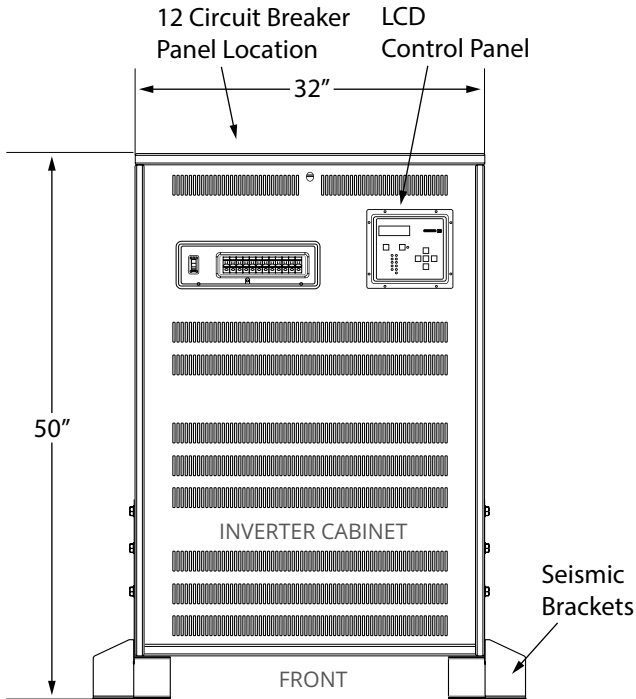
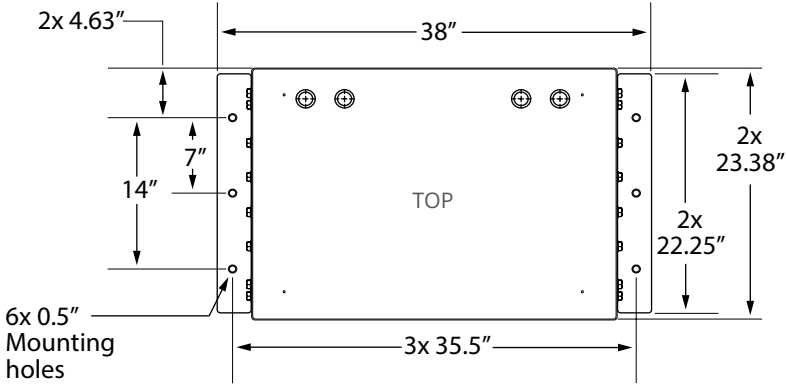

E3MAC-6000-1P

1,000-12,500 VA Single Phase Modular AC Inverter

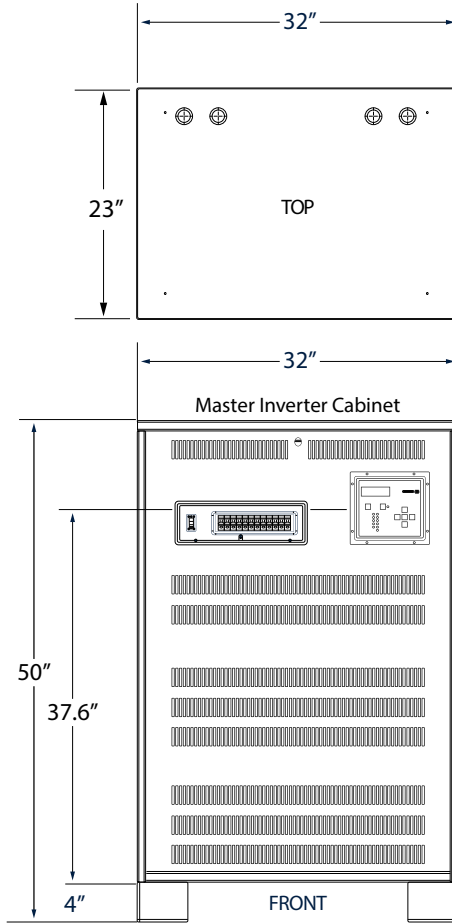

[VIEW SPEC SHEET](#)

WEIGHT					
# of Cabinets	Inverter Cabinet Weight (lbs)	Battery Cabinet Weight (lbs)	# of Batteries	# of Pallets	Total Weight
1	1280		12	2	1380

E3MAC-6000-1P

1,000-12,500 VA Single Phase Modular AC Inverter

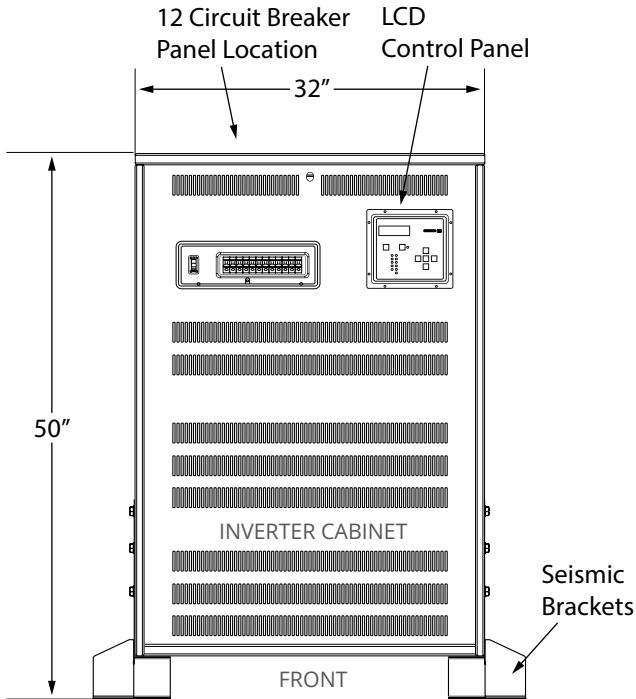
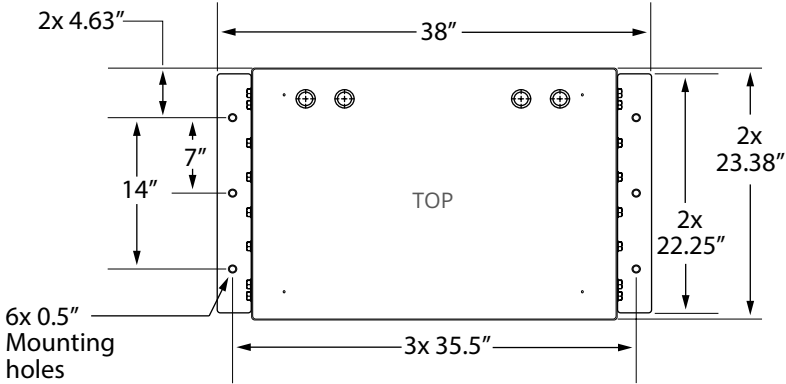

E3MAC-8000-1P

1,000-12,500 VA Single Phase Modular AC Inverter

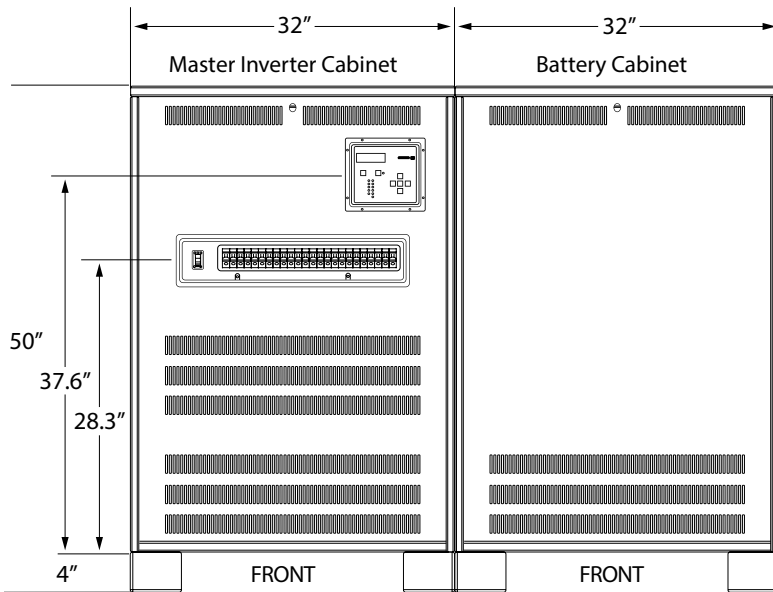
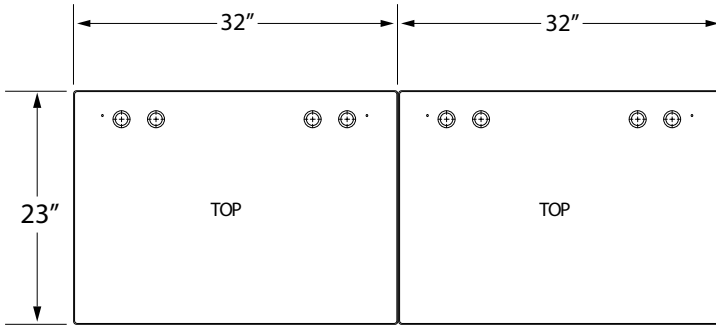

[VIEW SPEC SHEET](#)

WEIGHT					
# of Cabinets	Inverter Cabinet Weight (lbs)	Battery Cabinet Weight (lbs)	# of Batteries	# of Pallets	Total Weight
2	400	1570	16	3	2020



E3MAC-8000-1P

1,000-12,500 VA Single Phase Modular AC Inverter

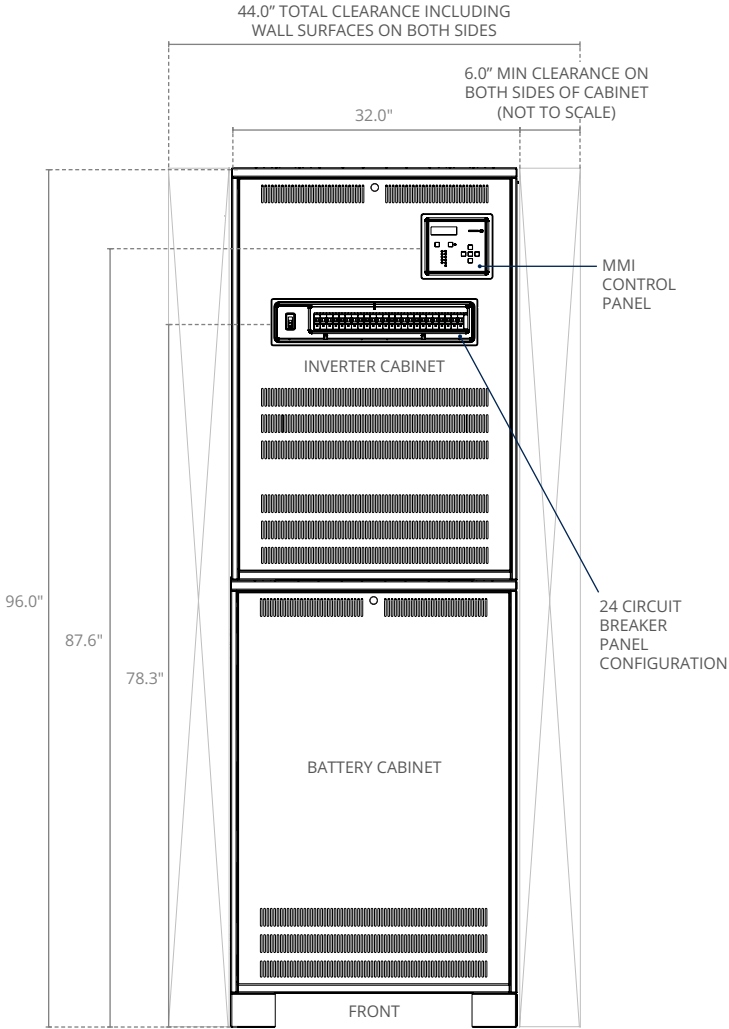

[VIEW SPEC SHEET](#)

WEIGHT					
# of Cabinets	Inverter Cabinet Weight (lbs)	Battery Cabinet Weight (lbs)	# of Batteries	# of Pallets	Total Weight
2	400	1570	16	3	2020

E3MAC-8000-1P

1,000-12,500 VA Single Phase Modular AC Inverter

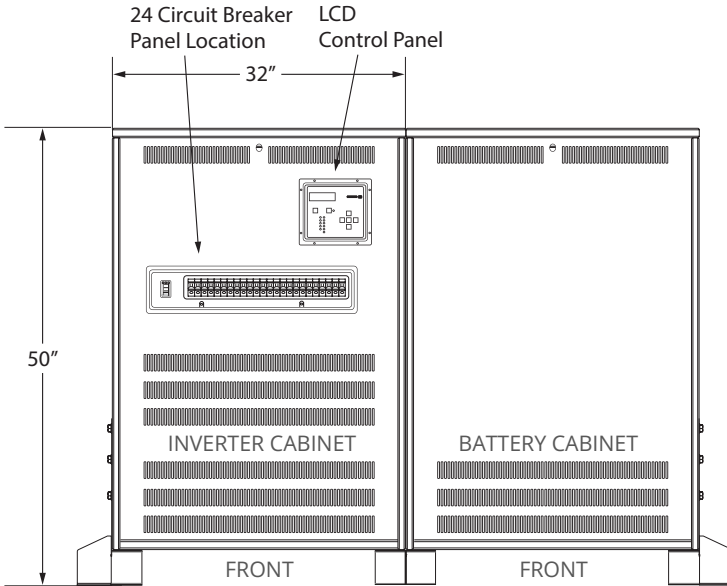
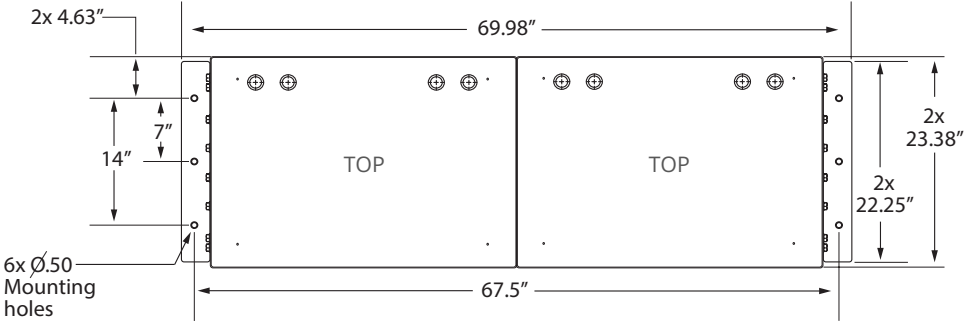

E3MAC-10000-1P

1,000-12,500 VA Single Phase Modular AC Inverter

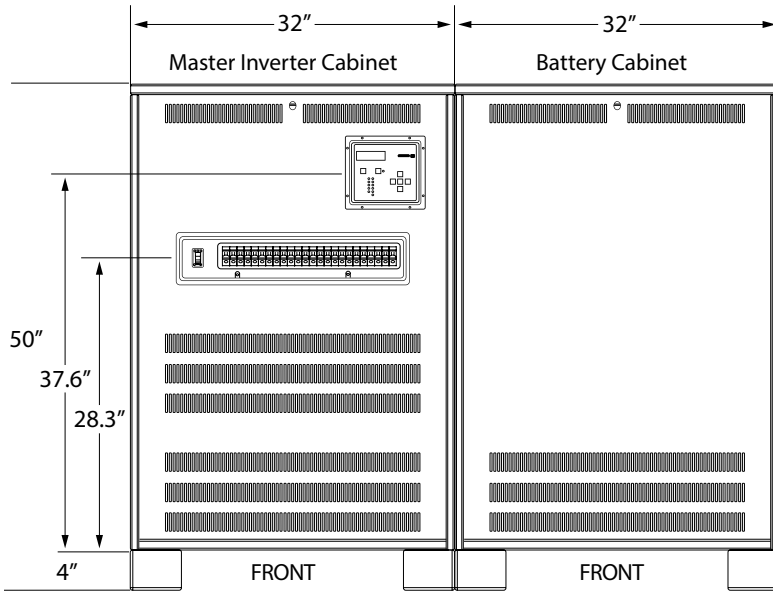
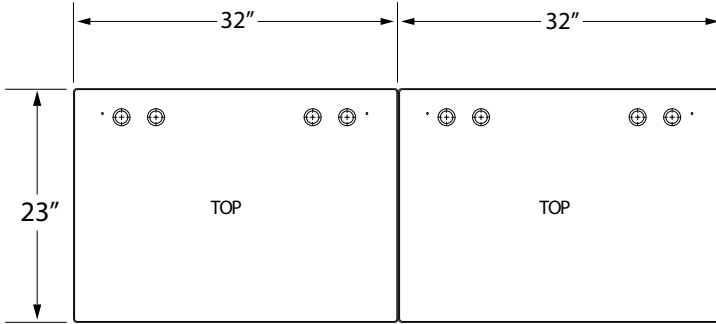

[VIEW SPEC SHEET](#)

WEIGHT					
# of Cabinets	Inverter Cabinet Weight (lbs)	Battery Cabinet Weight (lbs)	# of Batteries	# of Pallets	Total Weight
2	400	1890	20	3	2340



E3MAC-10000-1P

1,000-12,500 VA Single Phase Modular AC Inverter

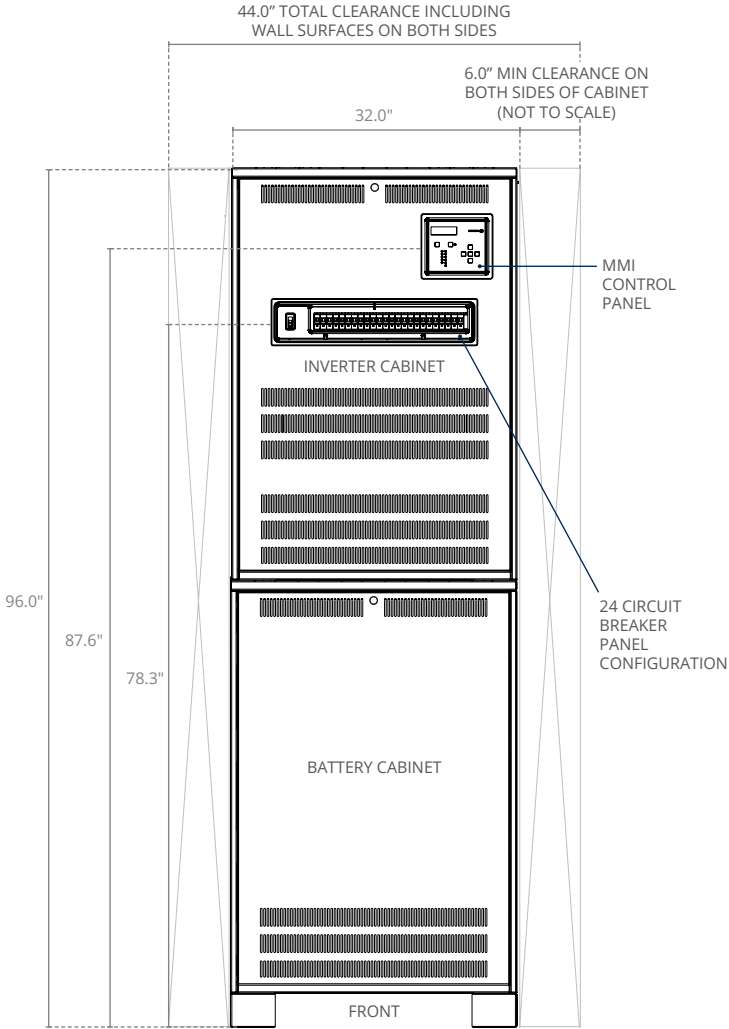

[VIEW SPEC SHEET](#)

WEIGHT					
# of Cabinets	Inverter Cabinet Weight (lbs)	Battery Cabinet Weight (lbs)	# of Batteries	# of Pallets	Total Weight
2	400	1890	20	3	2340

E3MAC-10000-1P

1,000-12,500 VA Single Phase Modular AC Inverter

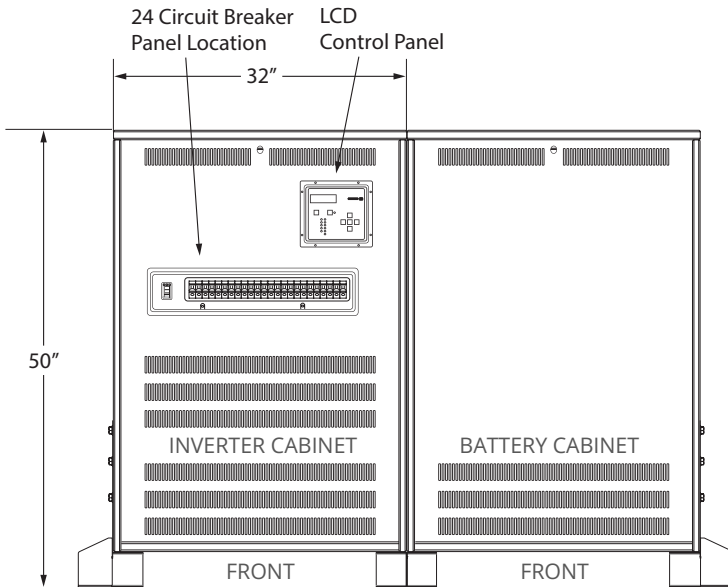
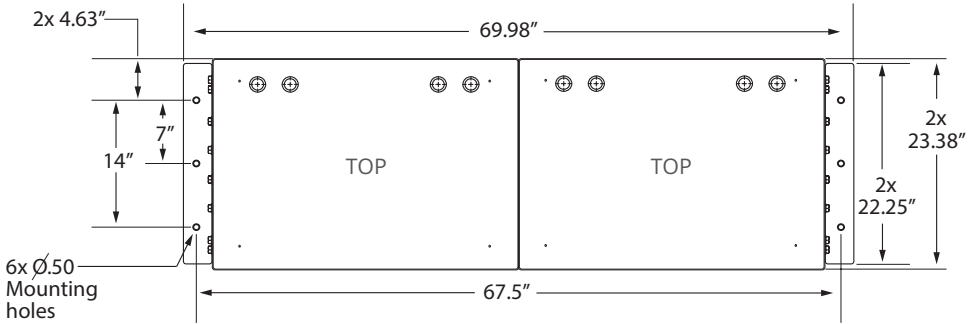

E3MAC-12500-1P

1,000-12,500 VA Single Phase Modular AC Inverter

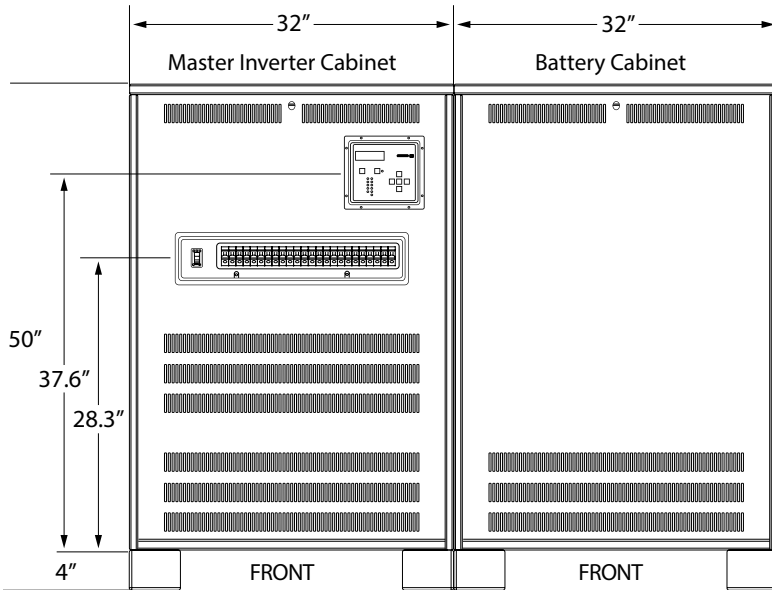
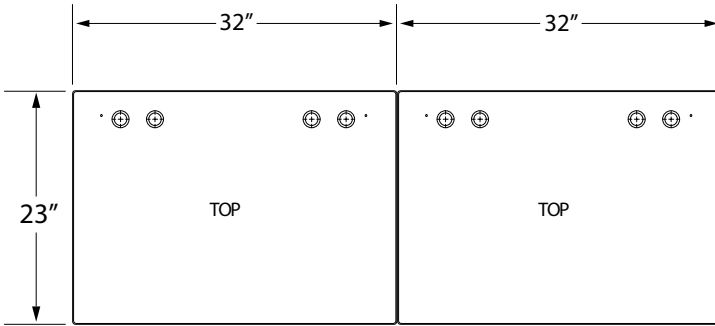

[VIEW SPEC SHEET](#)

WEIGHT					
# of Cabinets	Inverter Cabinet Weight (lbs)	Battery Cabinet Weight (lbs)	# of Batteries	# of Pallets	Total Weight
2	400	2210	24	3	2660



E3MAC-12500-1P

1,000-12,500 VA Single Phase Modular AC Inverter

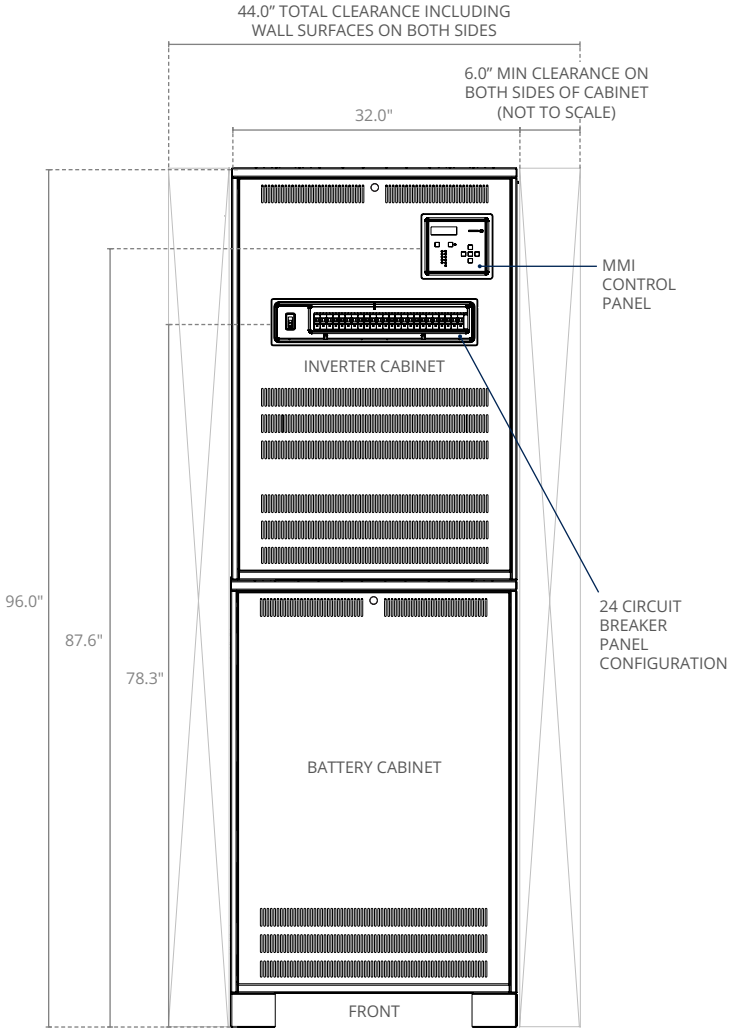

[VIEW SPEC SHEET](#)

WEIGHT					
# of Cabinets	Inverter Cabinet Weight (lbs)	Battery Cabinet Weight (lbs)	# of Batteries	# of Pallets	Total Weight
2	400	2210	24	3	2660

E3MAC-12500-1P

1,000-12,500 VA Single Phase Modular AC Inverter

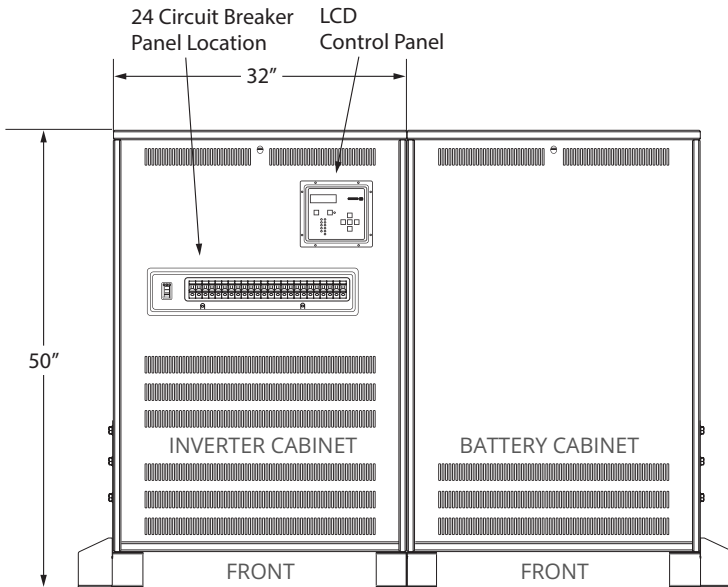
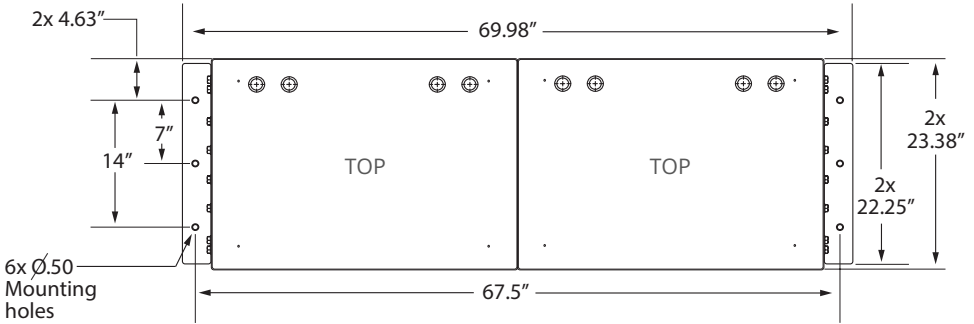

VIEW SPEC SHEET

E3MAC-3000-3P

3,000-18,000 VA Three Phase Modular AC Inverter

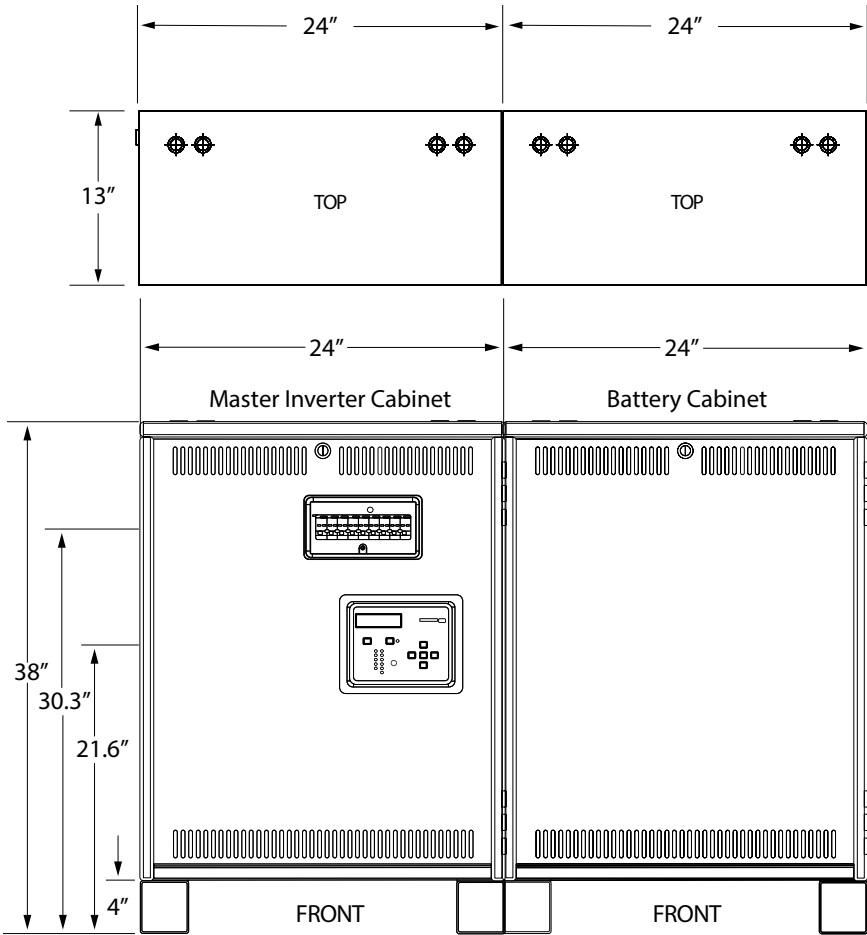

[VIEW SPEC SHEET](#)

WEIGHT					
# of Cabinets	Inverter Cabinet Weight (lbs)	Battery Cabinet Weight (lbs)	# of Batteries	# of Pallets	Total Weight
2	218	576	12	1	820



E3MAC-3000-3P

3,000-18,000 VA Three Phase Modular AC Inverter

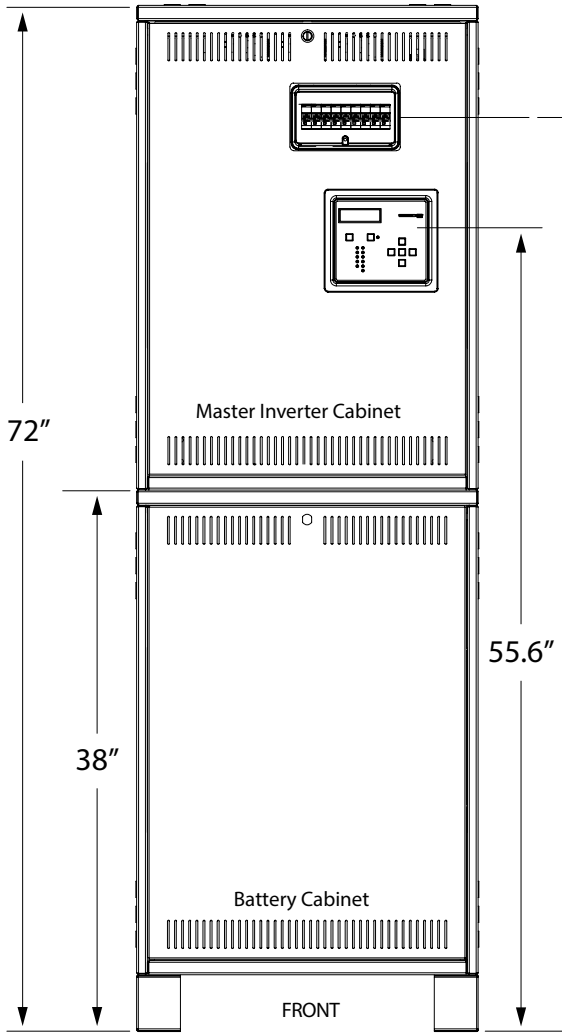

[VIEW SPEC SHEET](#)

WEIGHT					
# of Cabinets	Inverter Cabinet Weight (lbs)	Battery Cabinet Weight (lbs)	# of Batteries	# of Pallets	Total Weight
2	218	576	12	1	820

E3MAC-3000-3P

3,000-18,000 VA Three Phase Modular AC Inverter

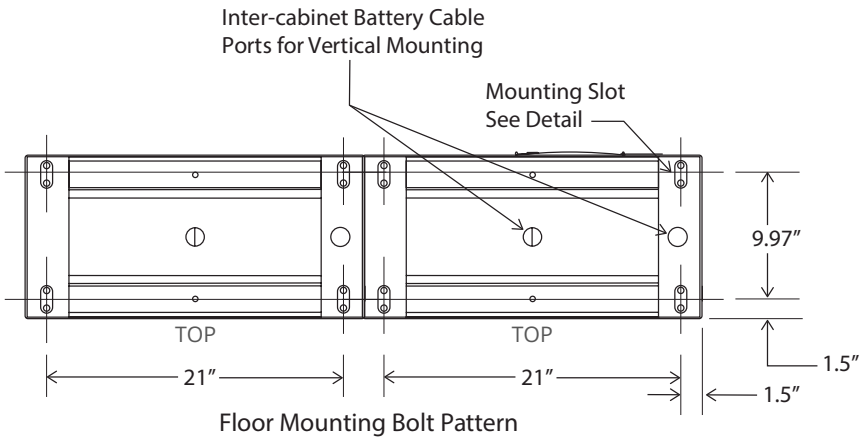

Battery Cabinet mounted to the right side of Inverter Cabinet for proper battery cable routing from cabinet to cabinet.

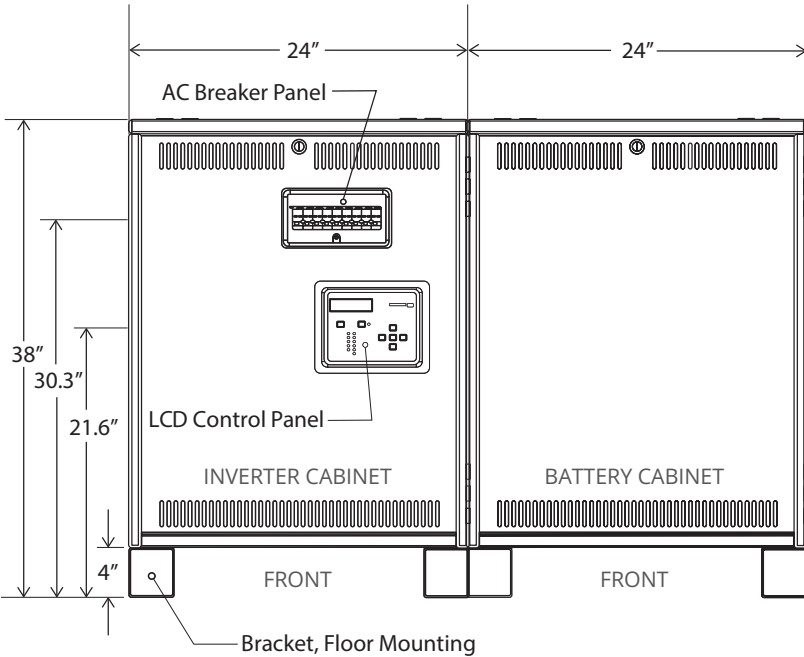

VIEW SPEC SHEET

E3MAC-4000-3P

3,000-18,000 VA Three Phase Modular AC Inverter

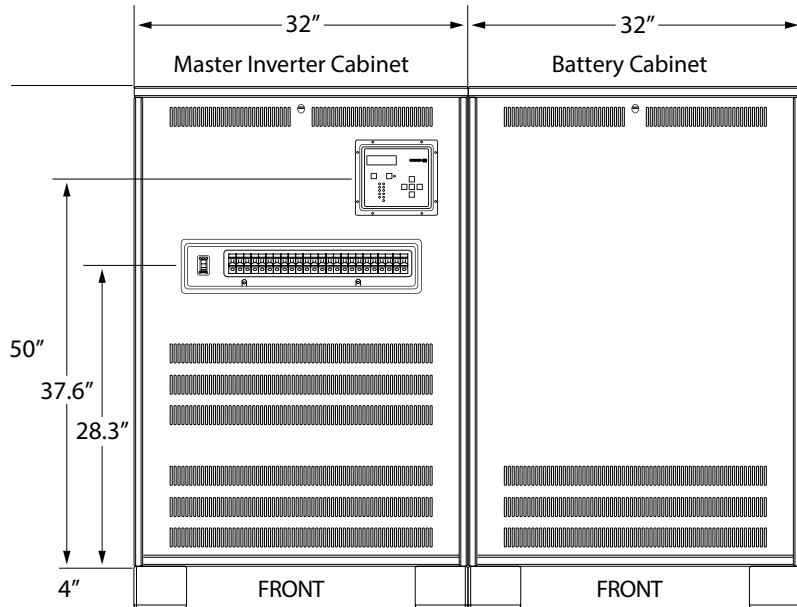
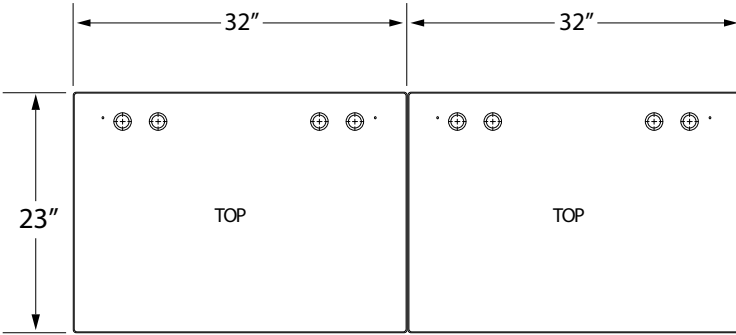

[VIEW SPEC SHEET](#)

WEIGHT

# of Cabinets	Inverter Cabinet Weight (lbs)	Battery Cabinet Weight (lbs)	# of Batteries	# of Pallets	Total Weight
2	565	900	8	3	1570



E3MAC-4000-3P

3,000-18,000 VA Three Phase Modular AC Inverter

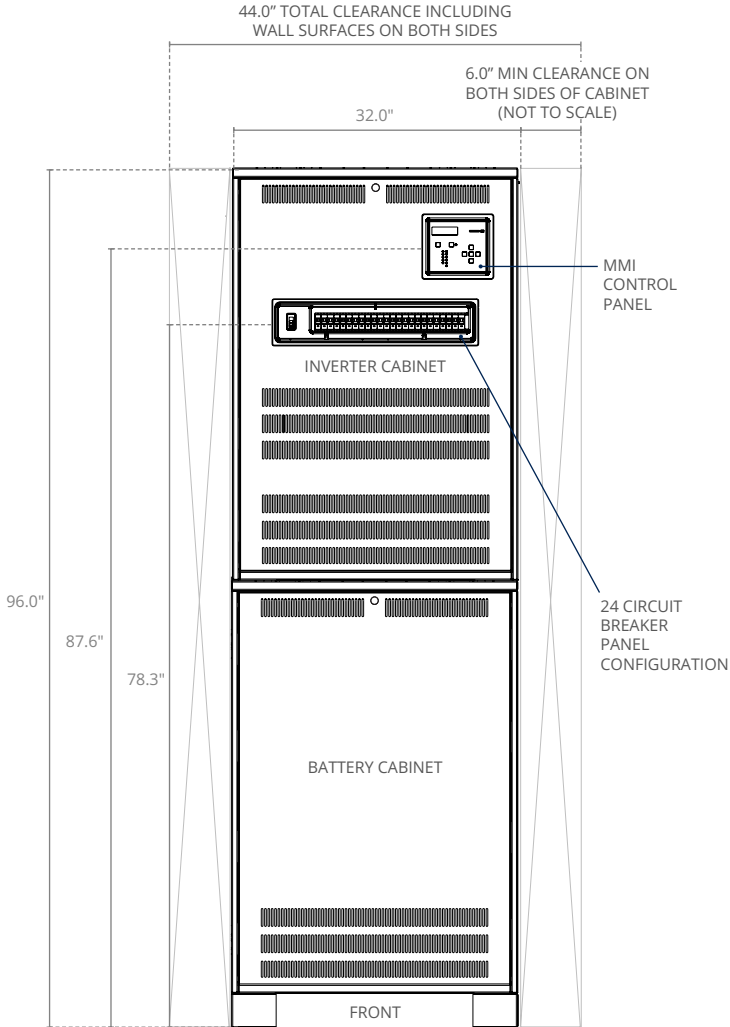

[VIEW SPEC SHEET](#)

WEIGHT					
# of Cabinets	Inverter Cabinet Weight (lbs)	Battery Cabinet Weight (lbs)	# of Batteries	# of Pallets	Total Weight
2	565	900	8	3	1570

E3MAC-4000-3P

3,000-18,000 VA Three Phase Modular AC Inverter

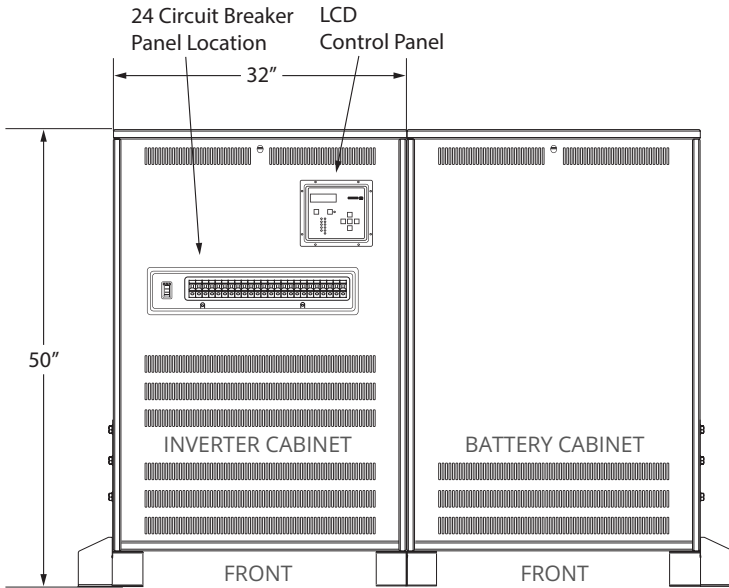
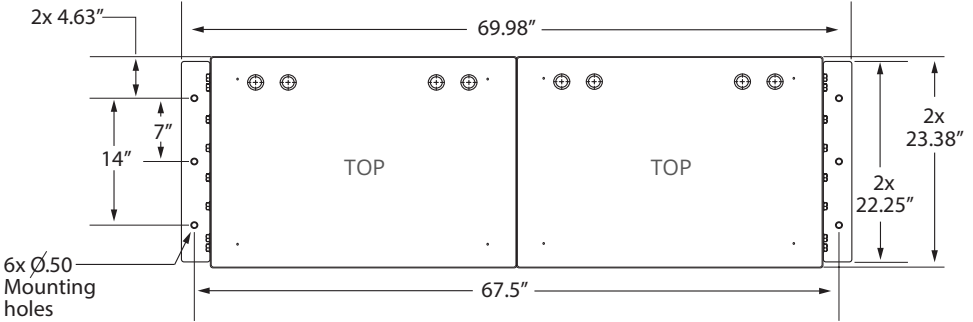

VIEW SPEC SHEET

E3MAC-5000-3P

3,000-18,000 VA Three Phase Modular AC Inverter

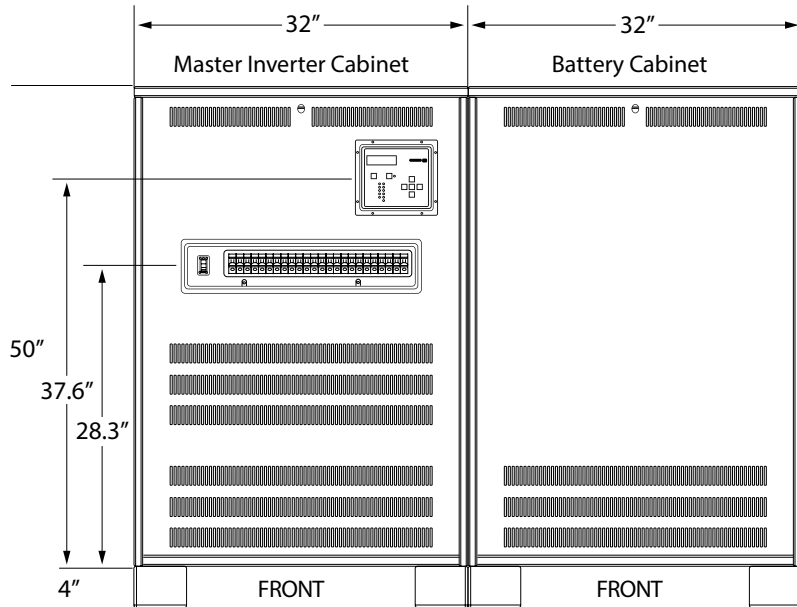
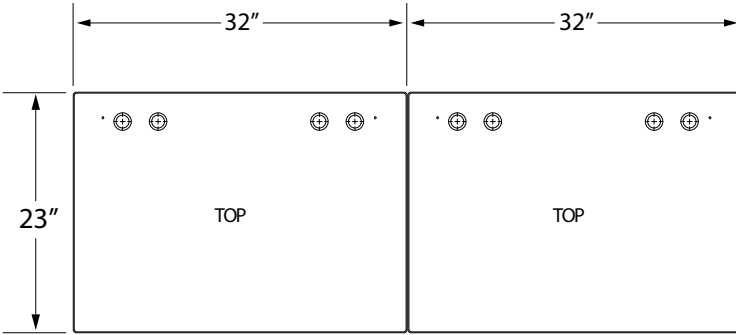

[VIEW SPEC SHEET](#)

WEIGHT

# of Cabinets	Inverter Cabinet Weight (lbs)	Battery Cabinet Weight (lbs)	# of Batteries	# of Pallets	Total Weight
2	565	1172	10	3	1737



E3MAC-5000-3P

3,000-18,000 VA Three Phase Modular AC Inverter

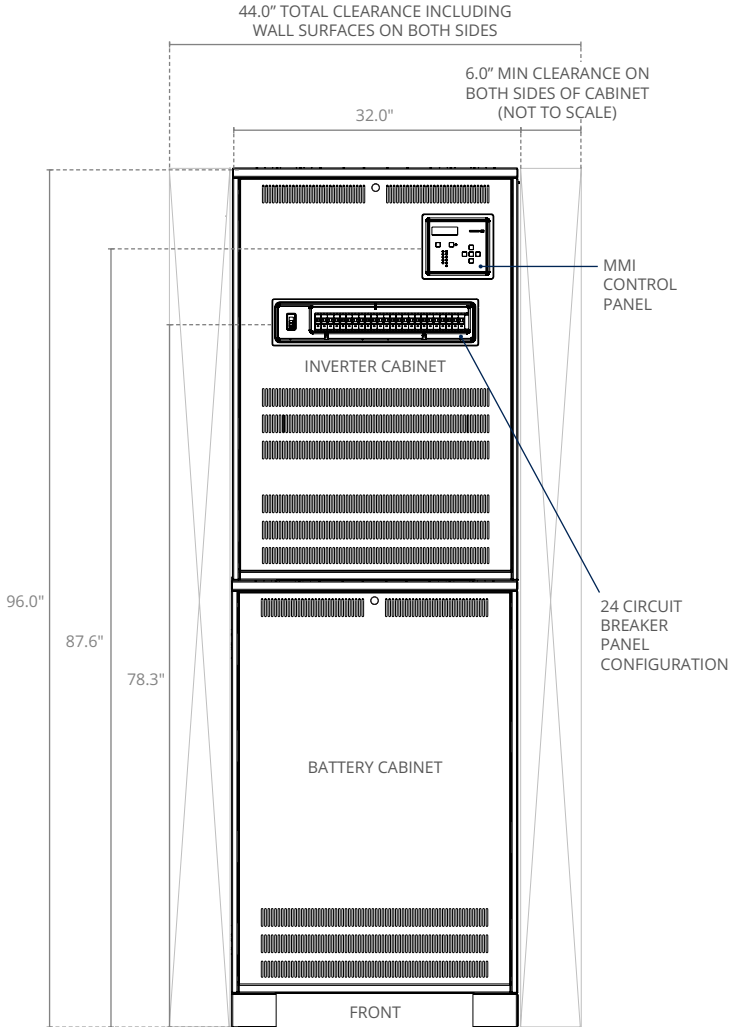

[VIEW SPEC SHEET](#)

WEIGHT					
# of Cabinets	Inverter Cabinet Weight (lbs)	Battery Cabinet Weight (lbs)	# of Batteries	# of Pallets	Total Weight
2	565	1172	10	3	1737

E3MAC-5000-3P

3,000-18,000 VA Three Phase Modular AC Inverter

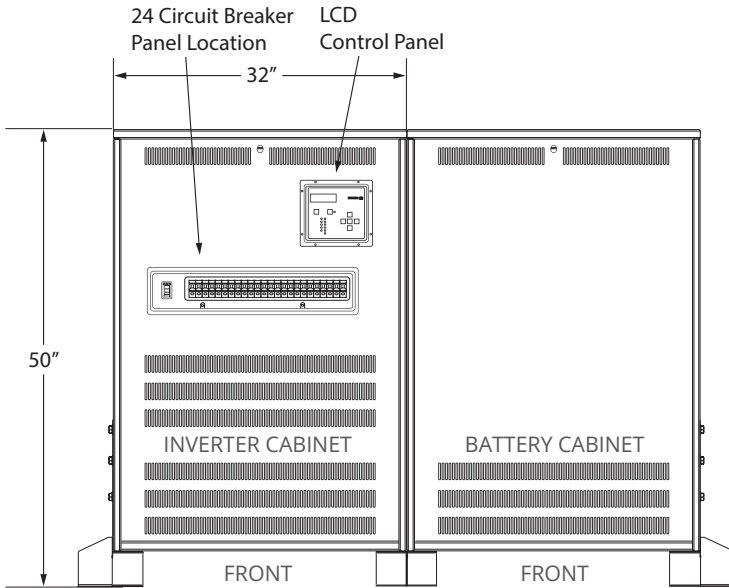
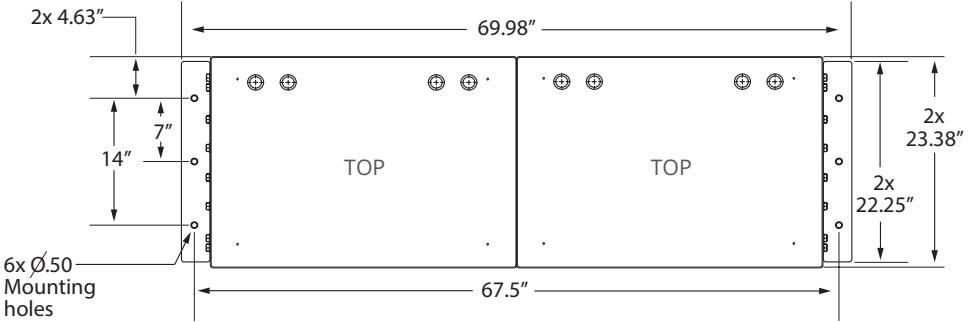

VIEW SPEC SHEET

E3MAC-6000-3P

3,000-18,000 VA Three Phase Modular AC Inverter

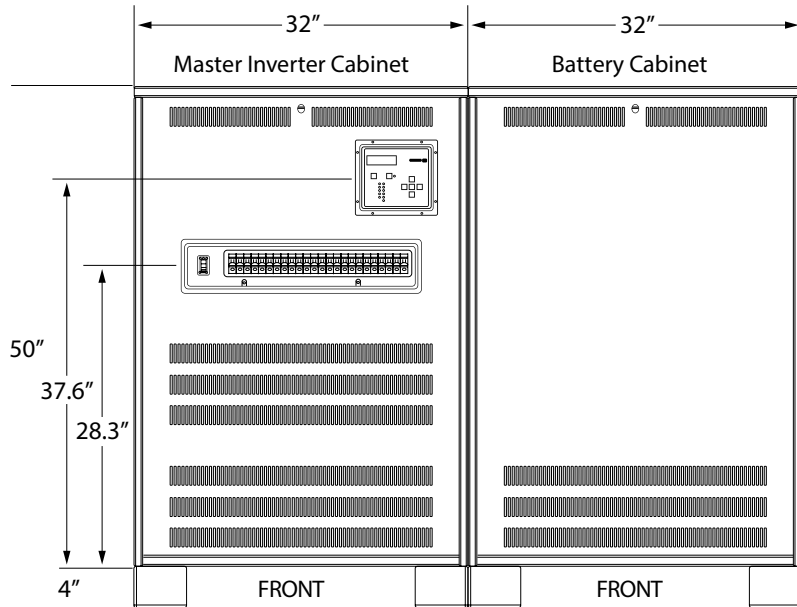
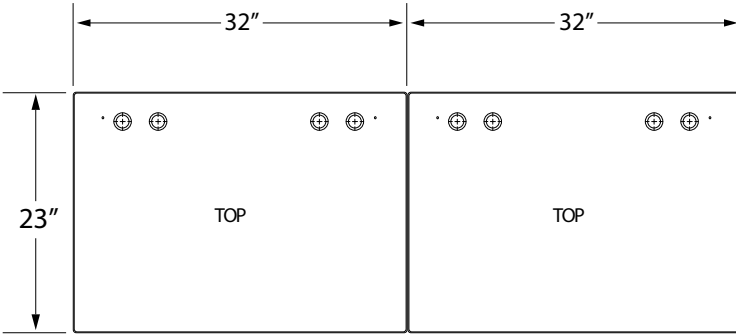

[VIEW SPEC SHEET](#)

WEIGHT

# of Cabinets	Inverter Cabinet Weight (lbs)	Battery Cabinet Weight (lbs)	# of Batteries	# of Pallets	Total Weight
2	565	1206	12	3	1976



E3MAC-6000-3P

3,000-18,000 VA Three Phase Modular AC Inverter

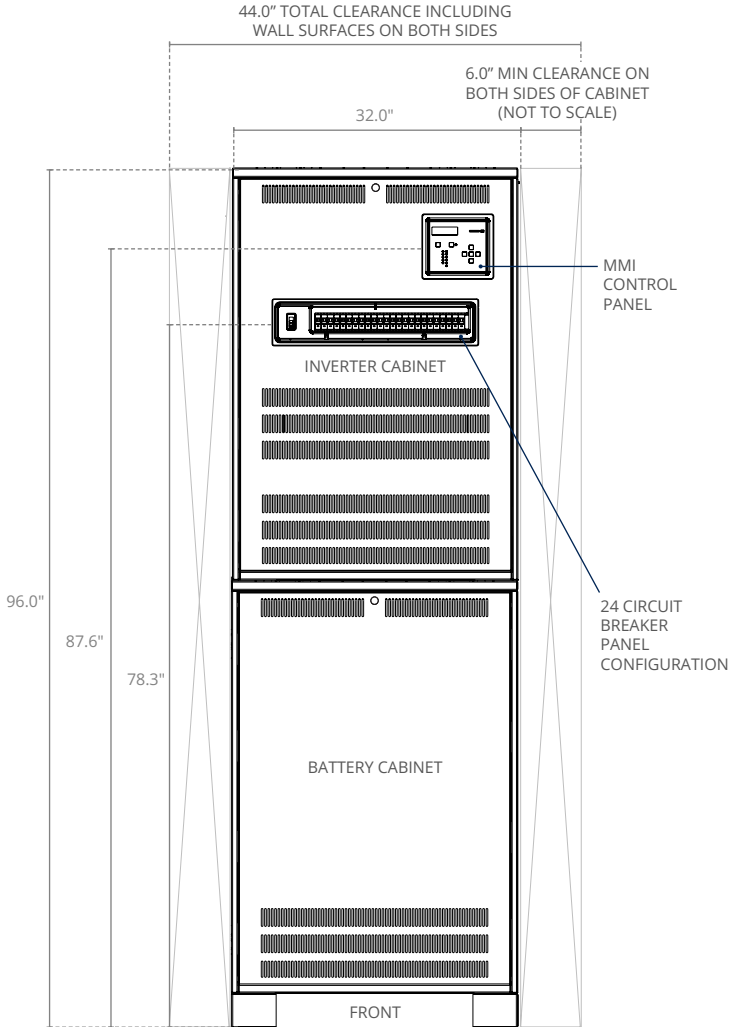

[VIEW SPEC SHEET](#)

WEIGHT					
# of Cabinets	Inverter Cabinet Weight (lbs)	Battery Cabinet Weight (lbs)	# of Batteries	# of Pallets	Total Weight
2	565	1206	12	3	1976

E3MAC-6000-3P

3,000-18,000 VA Three Phase Modular AC Inverter

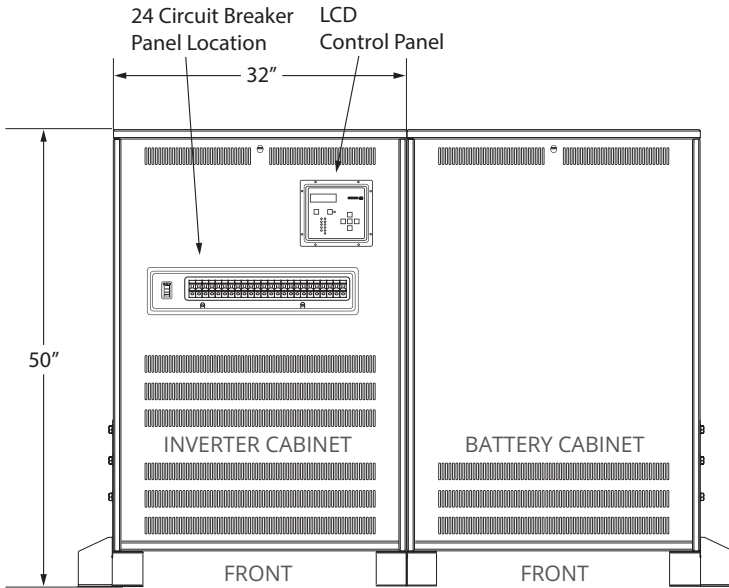
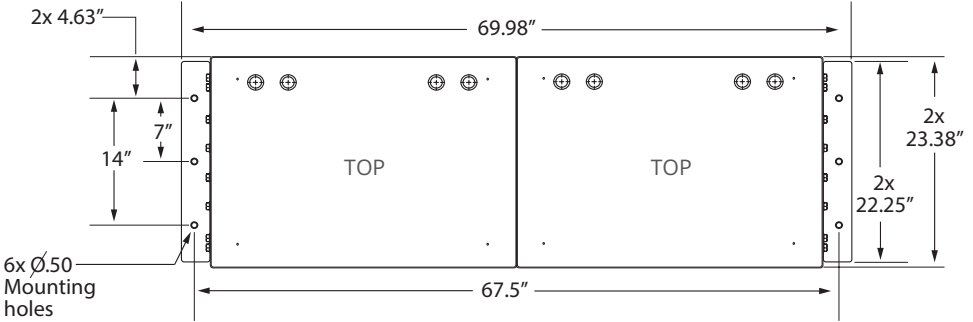

E3MAC-8000-3P

3,000-18,000 VA Three Phase Modular AC Inverter

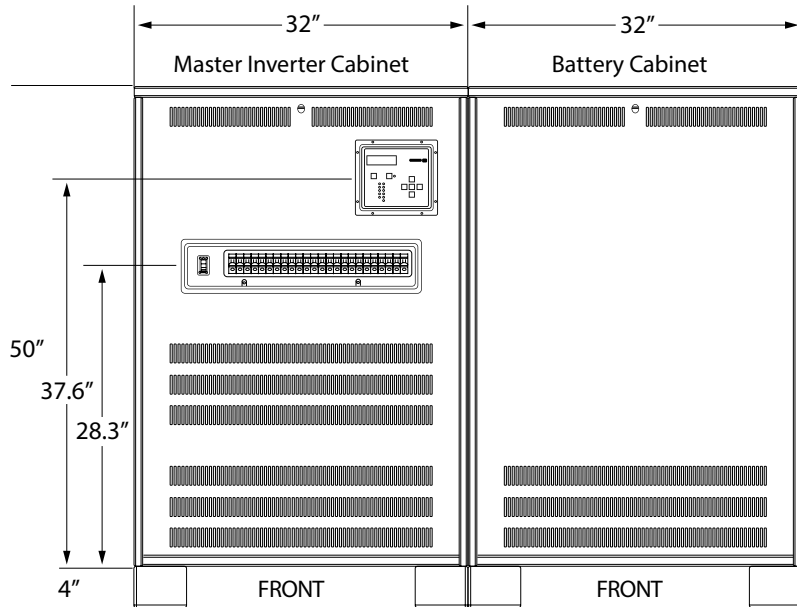
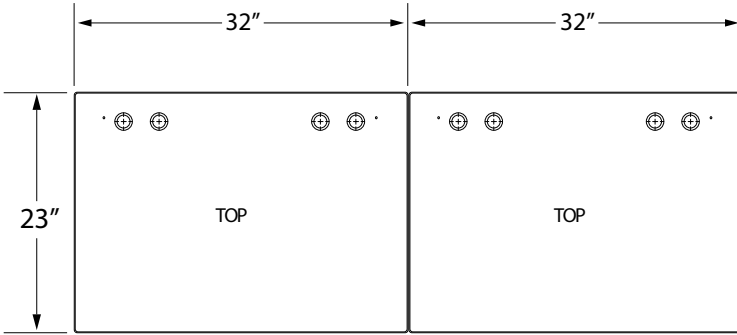

[VIEW SPEC SHEET](#)

WEIGHT

# of Cabinets	Inverter Cabinet Weight (lbs)	Battery Cabinet Weight (lbs)	# of Batteries	# of Pallets	Total Weight
2	565	1532	16	3	2210



E3MAC-8000-3P

3,000-18,000 VA Three Phase Modular AC Inverter

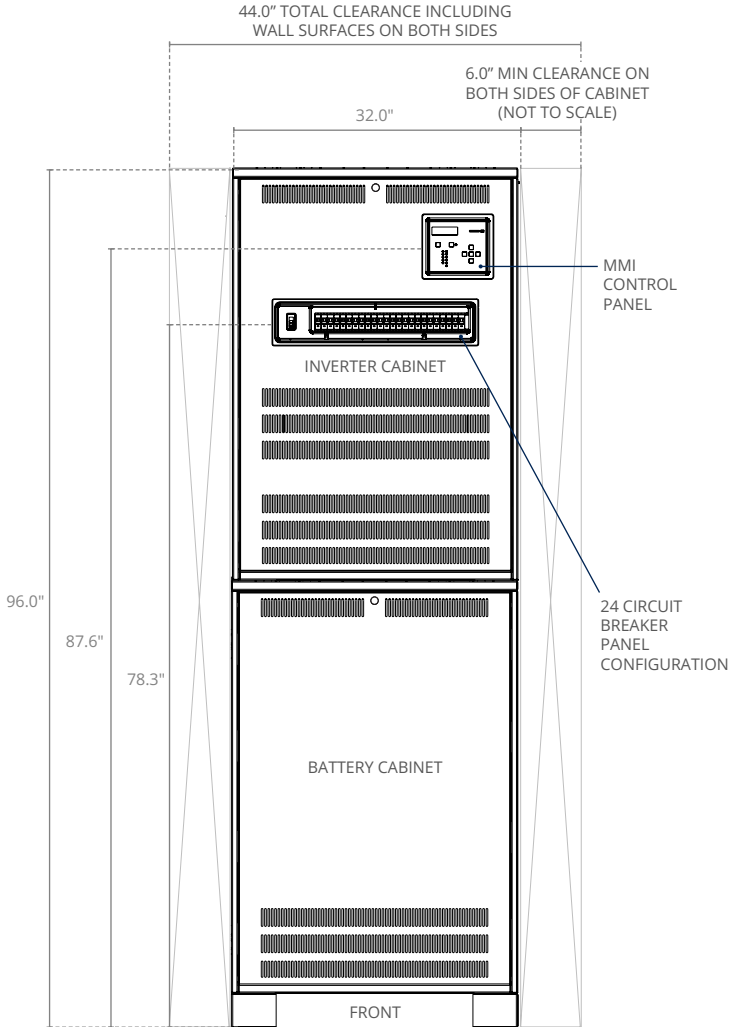

[VIEW SPEC SHEET](#)

WEIGHT					
# of Cabinets	Inverter Cabinet Weight (lbs)	Battery Cabinet Weight (lbs)	# of Batteries	# of Pallets	Total Weight
2	565	1532	16	3	2210

E3MAC-8000-3P

3,000-18,000 VA Three Phase Modular AC Inverter

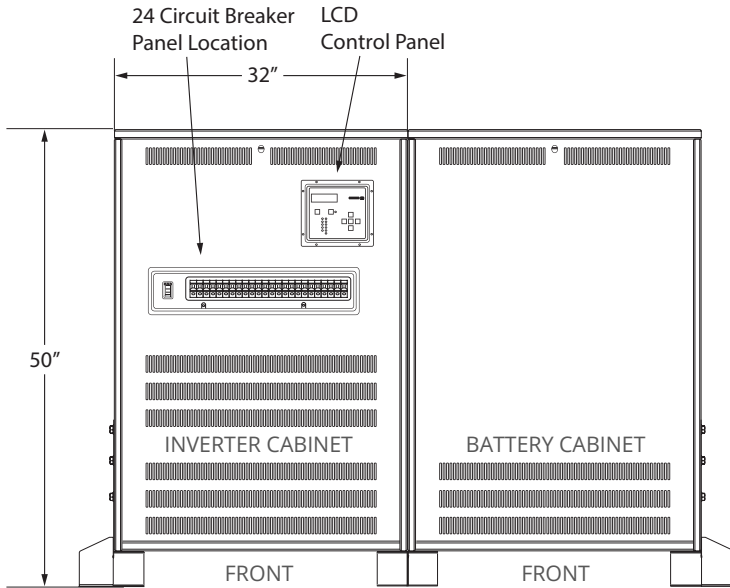
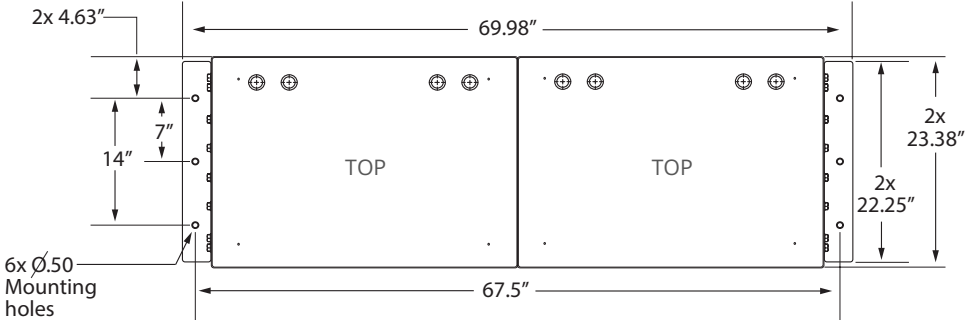

VIEW SPEC SHEET

E3MAC-10000-3P

3,000-18,000 VA Three Phase Modular AC Inverter

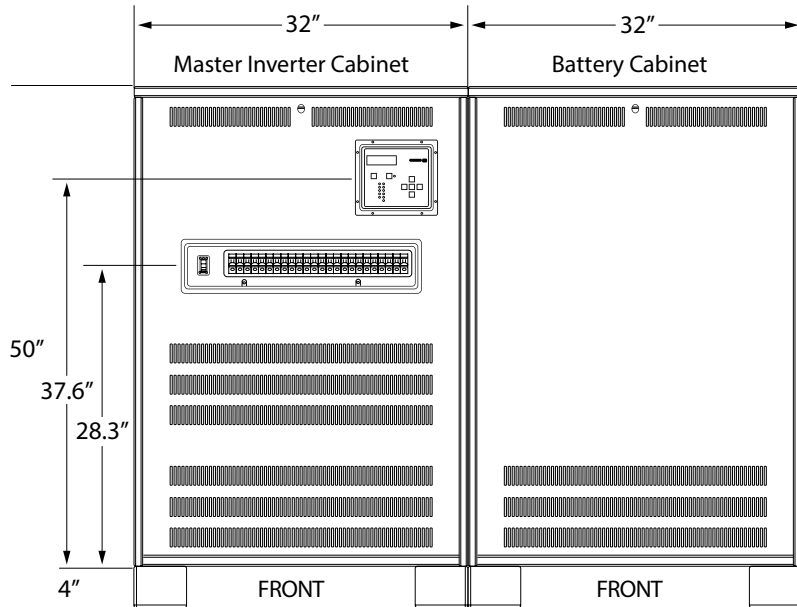
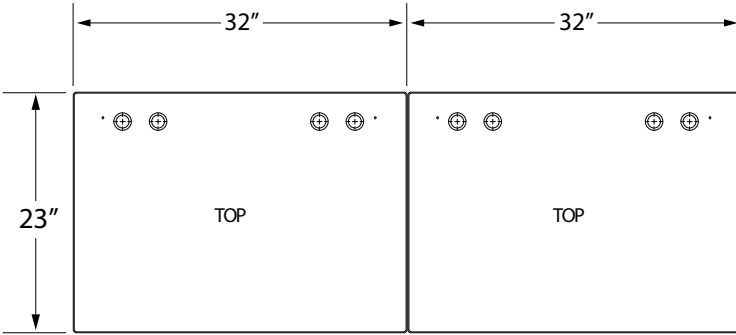

[VIEW SPEC SHEET](#)

WEIGHT

# of Cabinets	Inverter Cabinet Weight (lbs)	Battery Cabinet Weight (lbs)	# of Batteries	# of Pallets	Total Weight
2	565	1850	20	3	2530



E3MAC-10000-3P

3,000-18,000 VA Three Phase Modular AC Inverter

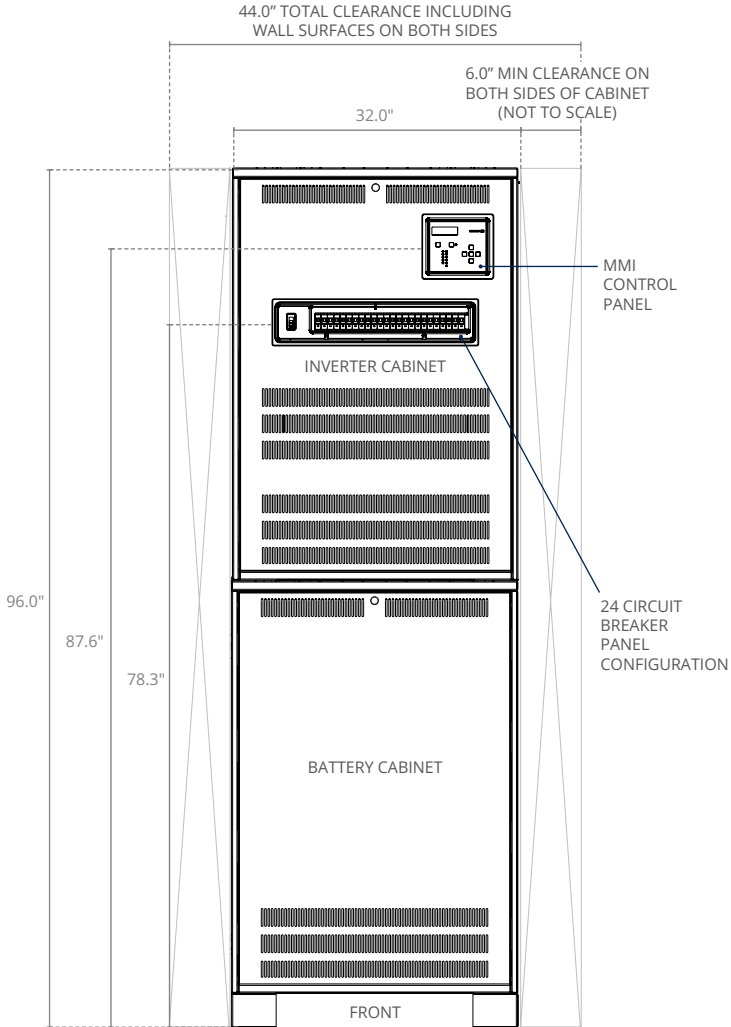

[VIEW SPEC SHEET](#)

WEIGHT					
# of Cabinets	Inverter Cabinet Weight (lbs)	Battery Cabinet Weight (lbs)	# of Batteries	# of Pallets	Total Weight
2	565	1850	20	3	2530

E3MAC-10000-3P

3,000-18,000 VA Three Phase Modular AC Inverter

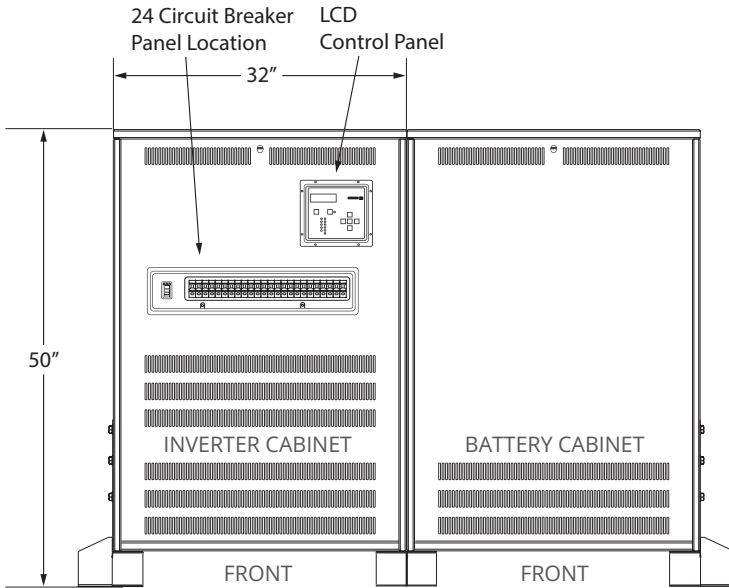
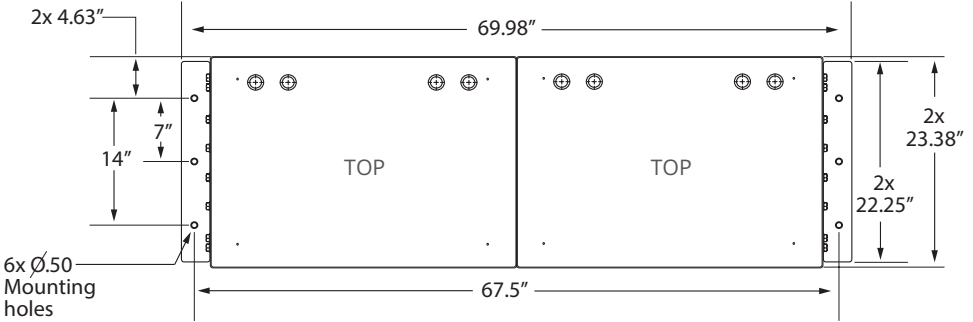

VIEW SPEC SHEET

E3MAC-12500-3P

3,000-18,000 VA Three Phase Modular AC Inverter

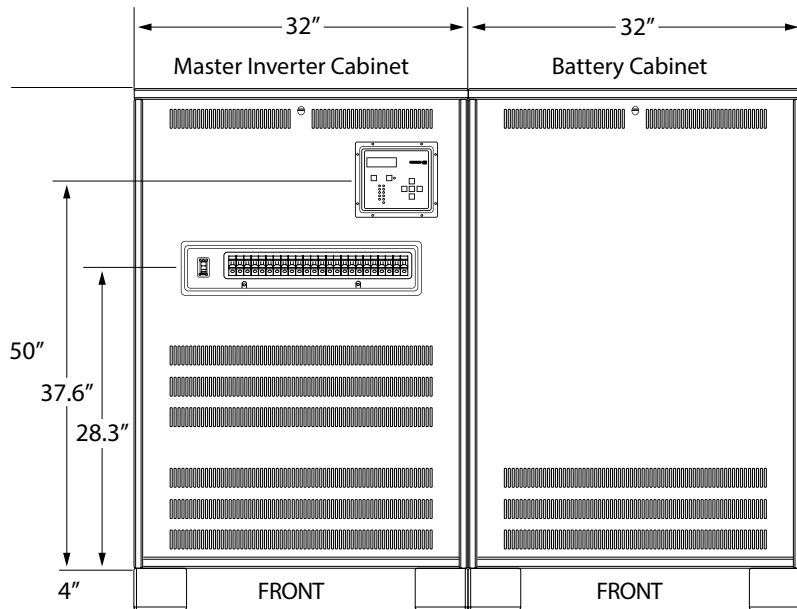
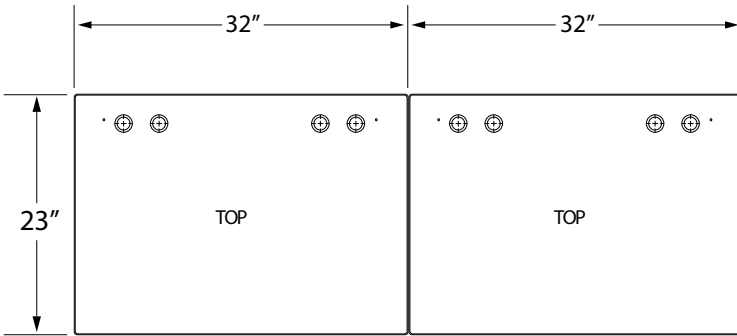

[VIEW SPEC SHEET](#)

WEIGHT

# of Cabinets	Inverter Cabinet Weight (lbs)	Battery Cabinet Weight (lbs)	# of Batteries	# of Pallets	Total Weight
2	565	2161	24	5	2850



E3MAC-12500-3P

3,000-18,000 VA Three Phase Modular AC Inverter

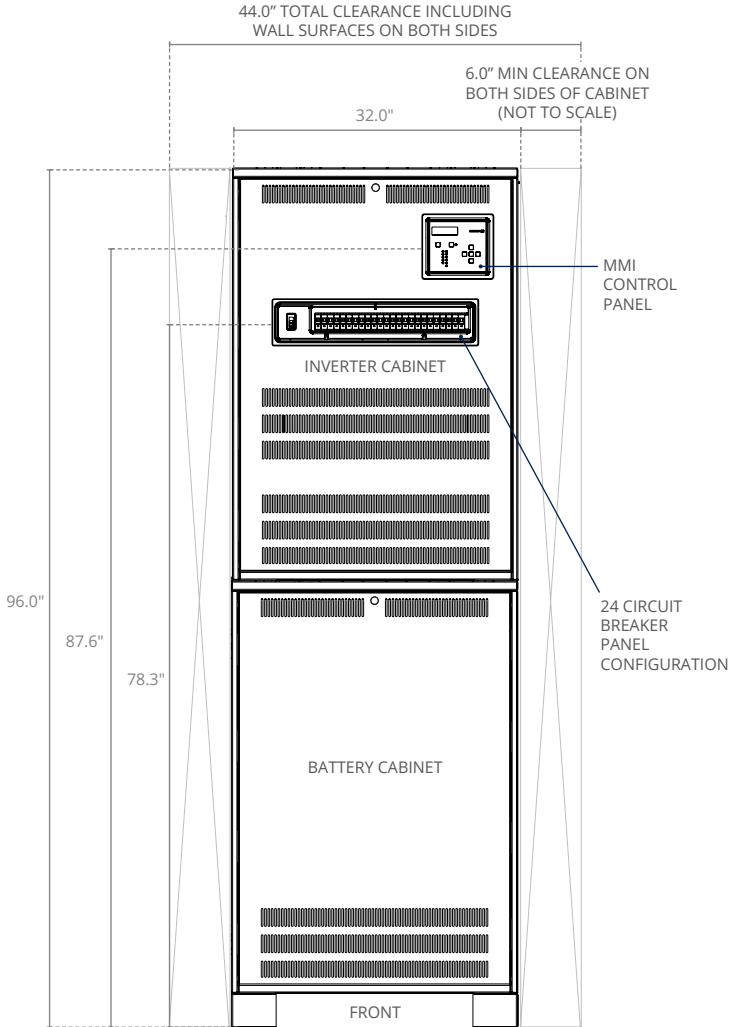

[VIEW SPEC SHEET](#)

WEIGHT					
# of Cabinets	Inverter Cabinet Weight (lbs)	Battery Cabinet Weight (lbs)	# of Batteries	# of Pallets	Total Weight
2	565	2161	24	5	2850

E3MAC-12500-3P

3,000-18,000 VA Three Phase Modular AC Inverter

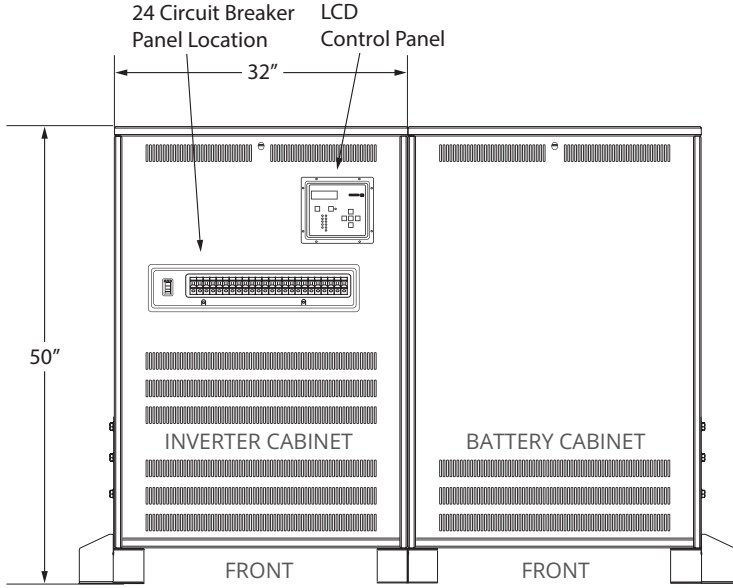
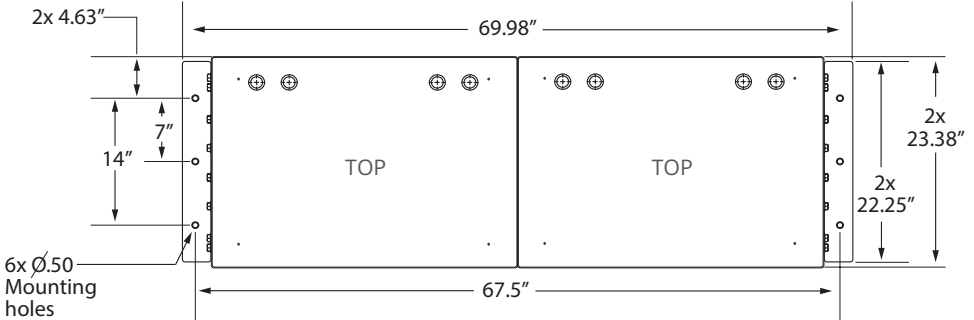

E3MAC-15000-3P

3,000-18,000 VA Three Phase Modular AC Inverter

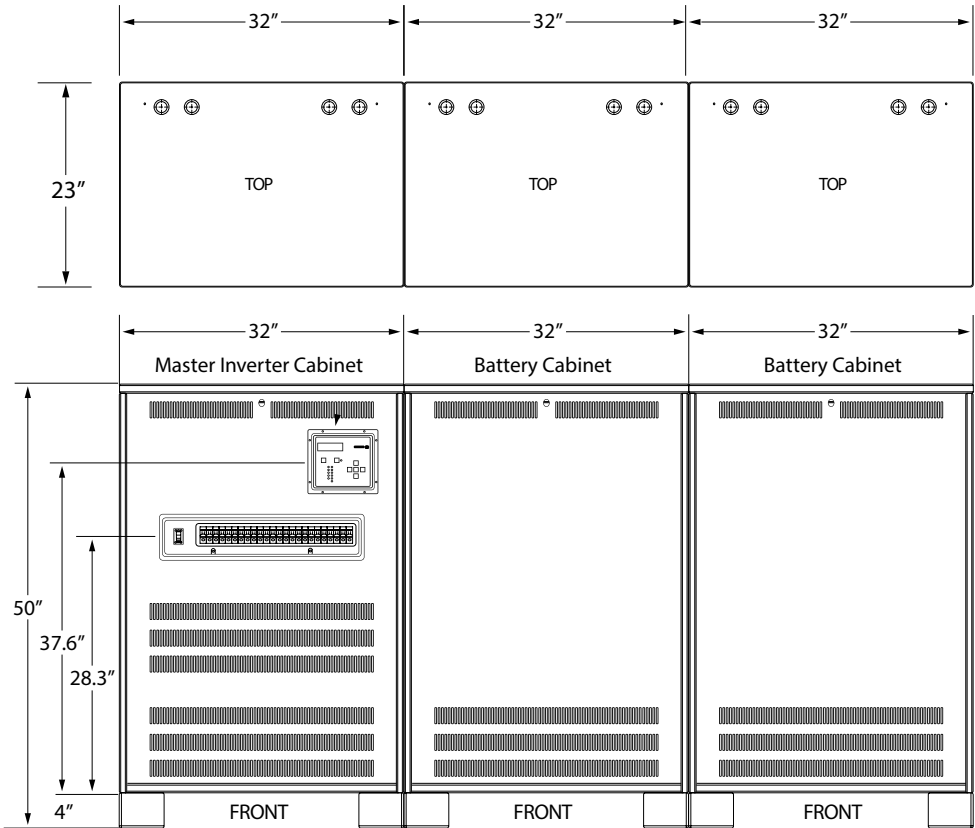

[VIEW SPEC SHEET](#)

WEIGHT					
# of Cabinets	Inverter Cabinet Weight (lbs)	Battery Cabinet Weight (lbs)	# of Batteries	# of Pallets	Total Weight
3	565	2908	30	5	3630

E3MAC-15000-3P

3,000-18,000 VA Three Phase Modular AC Inverter

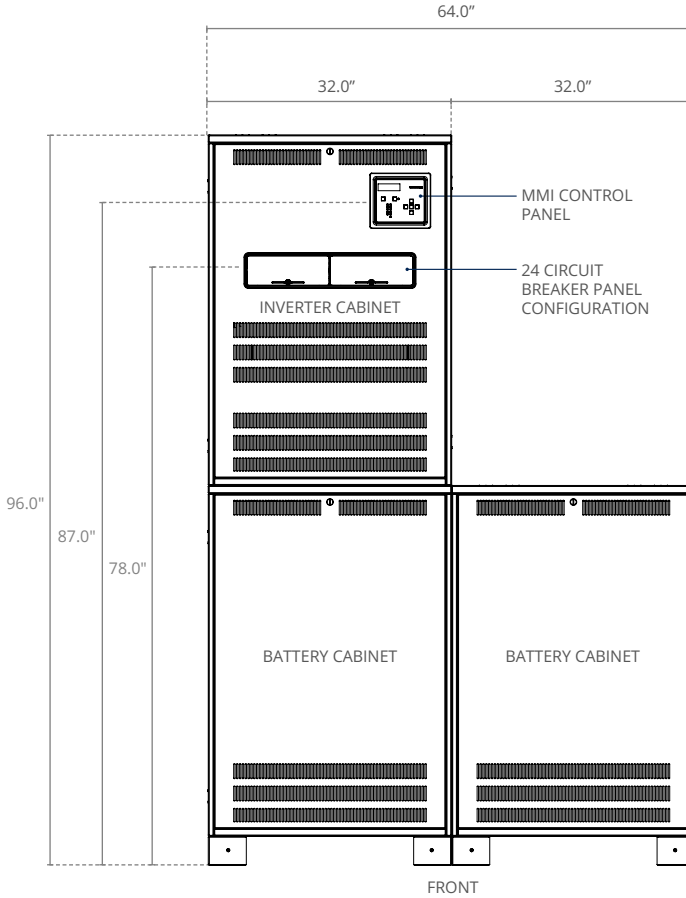

[VIEW SPEC SHEET](#)

WEIGHT					
# of Cabinets	Inverter Cabinet Weight (lbs)	Battery Cabinet Weight (lbs)	# of Batteries	# of Pallets	Total Weight
3	565	2908	30	5	3630

E3MAC-15000-3P

3,000-18,000 VA Three Phase Modular AC Inverter

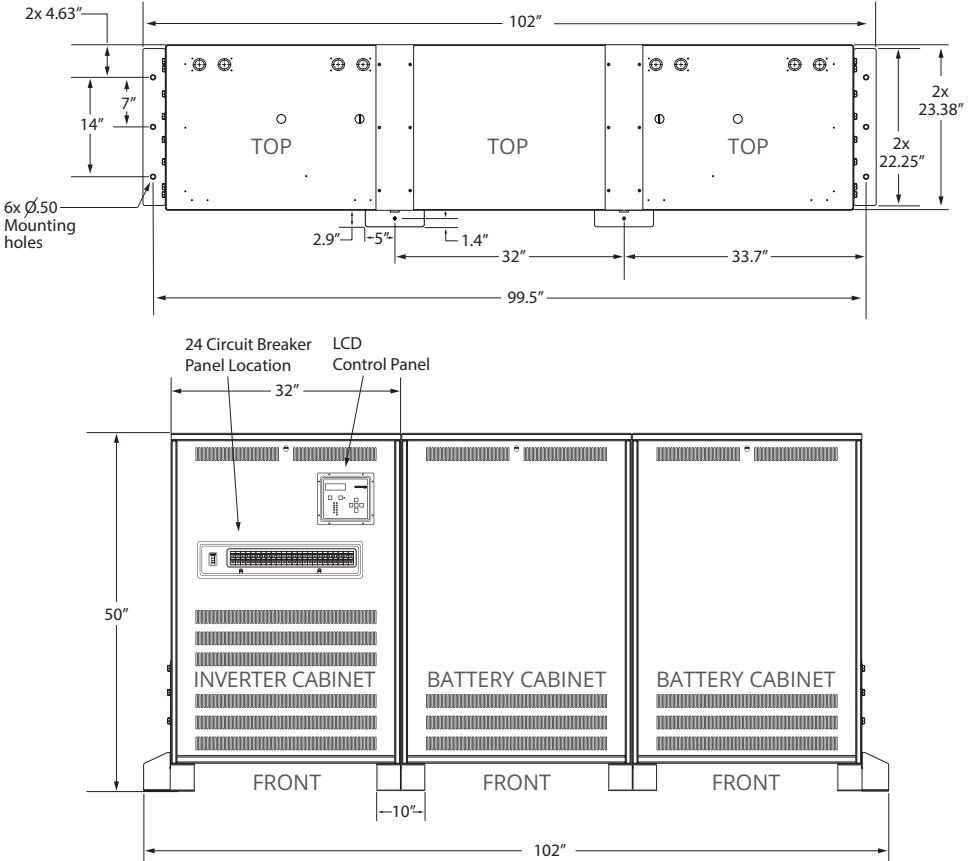

VIEW SPEC SHEET

E3MAC-18000-3P

3,000-18,000 VA Three Phase Modular AC Inverter

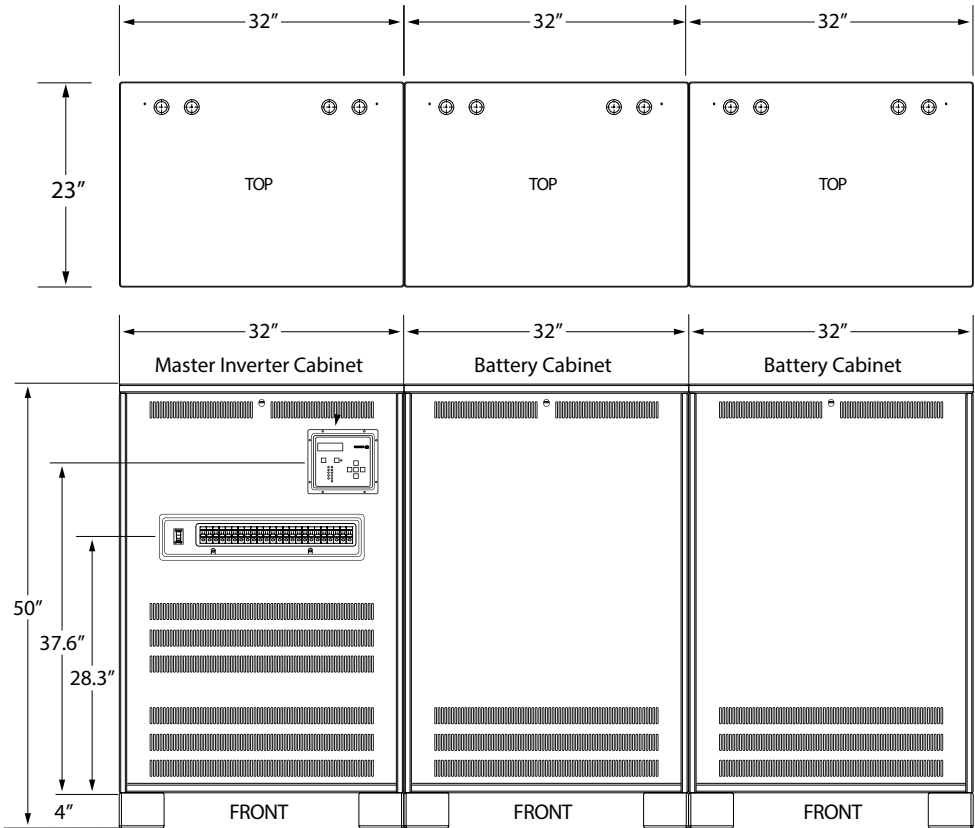

[VIEW SPEC SHEET](#)

WEIGHT					
# of Cabinets	Inverter Cabinet Weight (lbs)	Battery Cabinet Weight (lbs)	# of Batteries	# of Pallets	Total Weight
3	565	3560	36	5	4150

E3MAC-18000-3P

3,000-18,000 VA Three Phase Modular AC Inverter

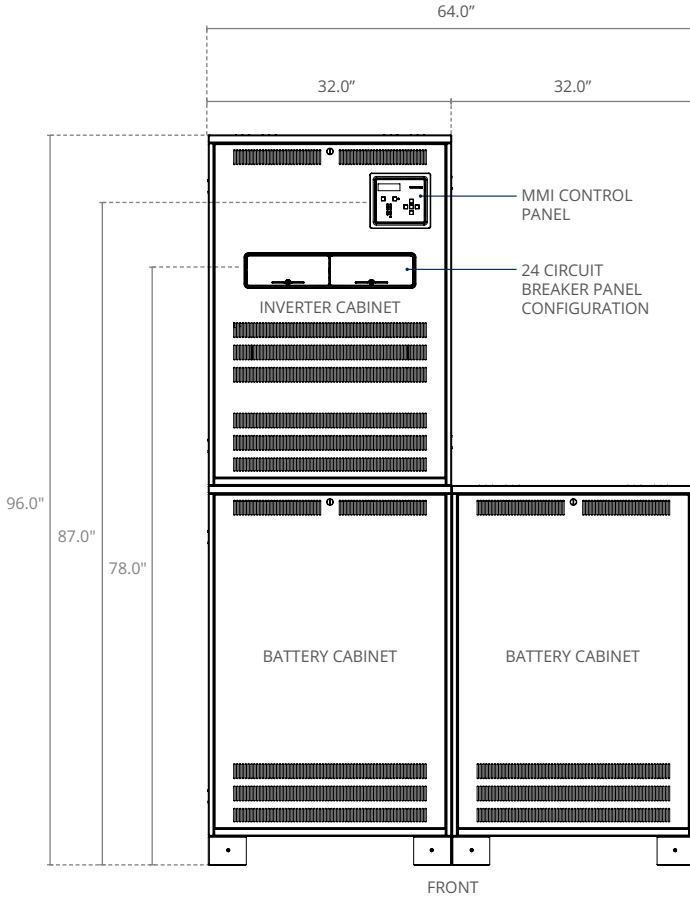

[VIEW SPEC SHEET](#)

WEIGHT					
# of Cabinets	Inverter Cabinet Weight (lbs)	Battery Cabinet Weight (lbs)	# of Batteries	# of Pallets	Total Weight
3	565	3560	36	5	4150

E3MAC-18000-3P

3,000-18,000 VA Three Phase Modular AC Inverter

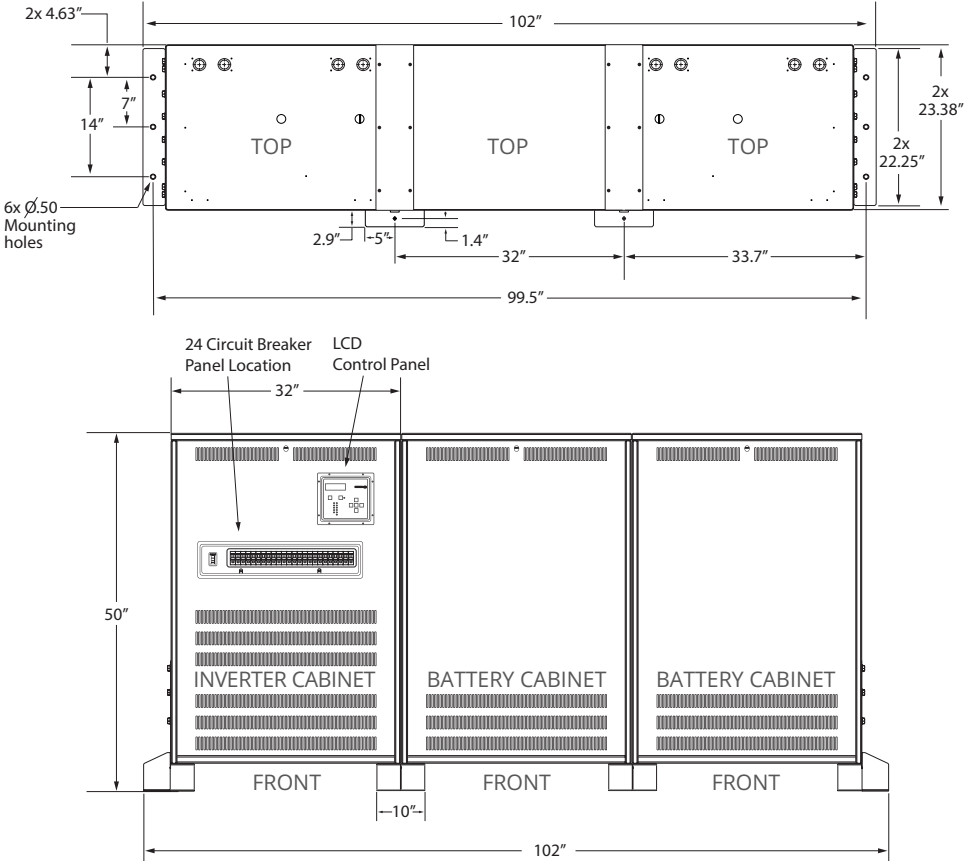

VIEW SPEC SHEET



E3MAX-13300-1P

13,300-17,000 VA Single Phase Modular AC Inverter

2 CABINETS

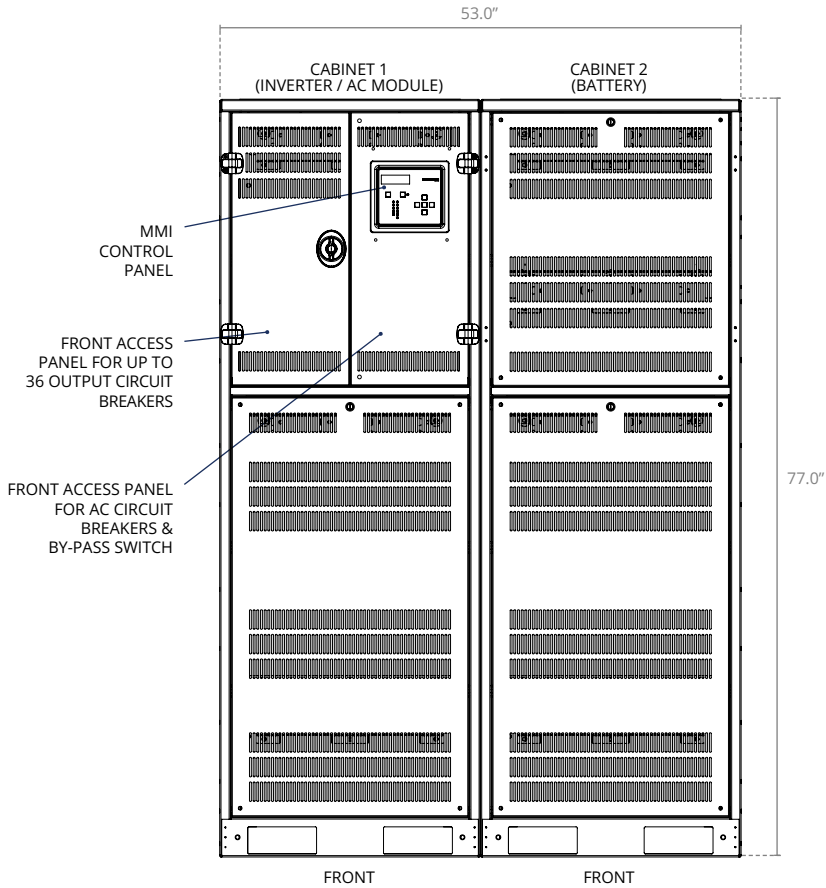

RETURN TO SIZES

VIEW SPEC SHEET

WEIGHT				
# of Cabinets	Inverter Cabinet Weight (lbs)	Battery Cabinet Weight (lbs)	Shipping Weight (lbs)	# of Batteries
2	790	2336	3161	16

E3MAX-13300-1P

13,300-17,000 VA Single Phase Modular AC Inverter

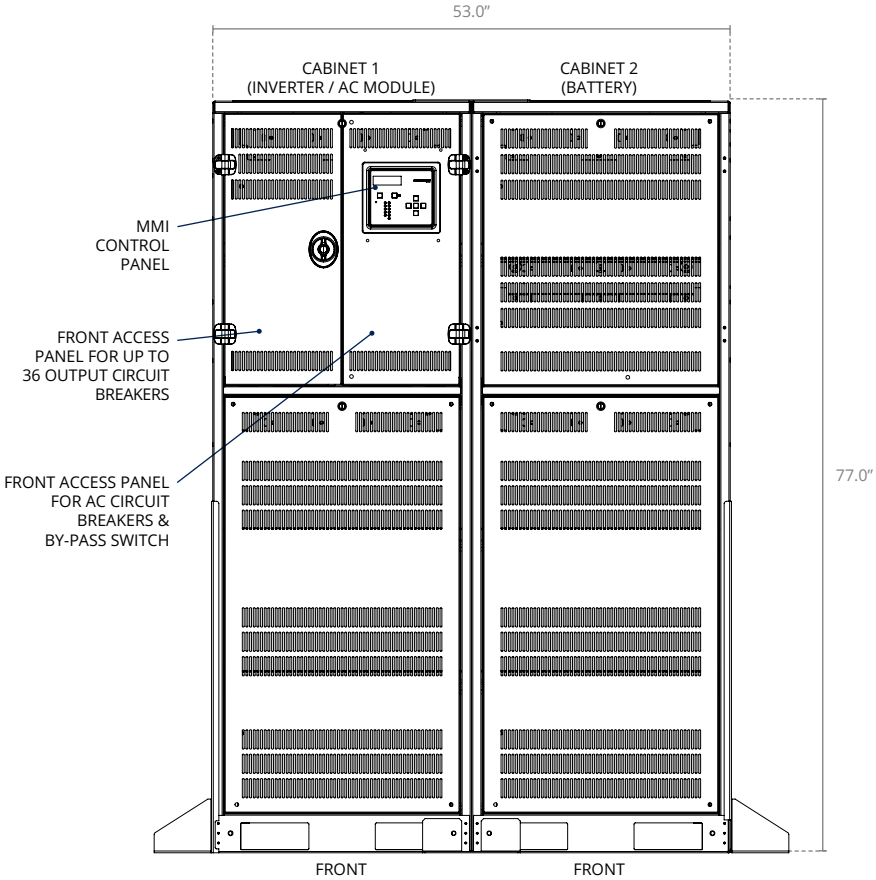

VIEW SPEC SHEET

WEIGHT				
# of Cabinets	Inverter Cabinet Weight (lbs)	Battery Cabinet Weight (lbs)	Shipping Weight (lbs)	# of Batteries
2	790	2336	3161	16



E3MAX-17000-1P

13,300-17,000 VA Single Phase Modular AC Inverter

2 CABINETS

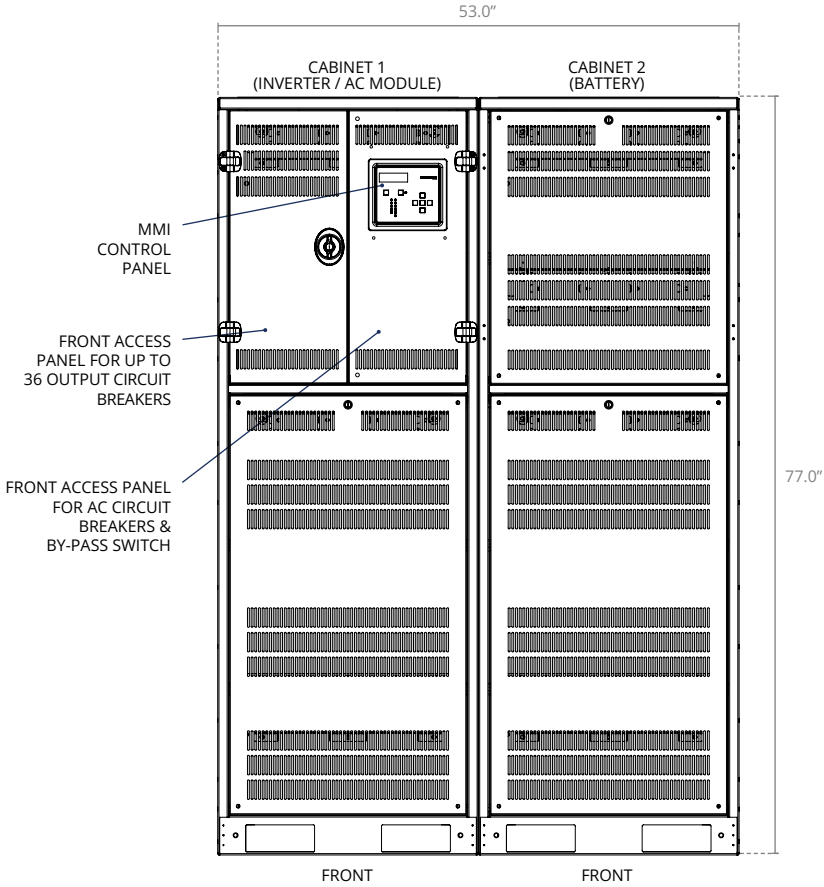

RETURN TO SIZES

VIEW SPEC SHEET

WEIGHT				
# of Cabinets	Inverter Cabinet Weight (lbs)	Battery Cabinet Weight (lbs)	Shipping Weight (lbs)	# of Batteries
2	790	2820	3645	20

E3MAX-17000-1P

13,300-17,000 VA Single Phase Modular AC Inverter

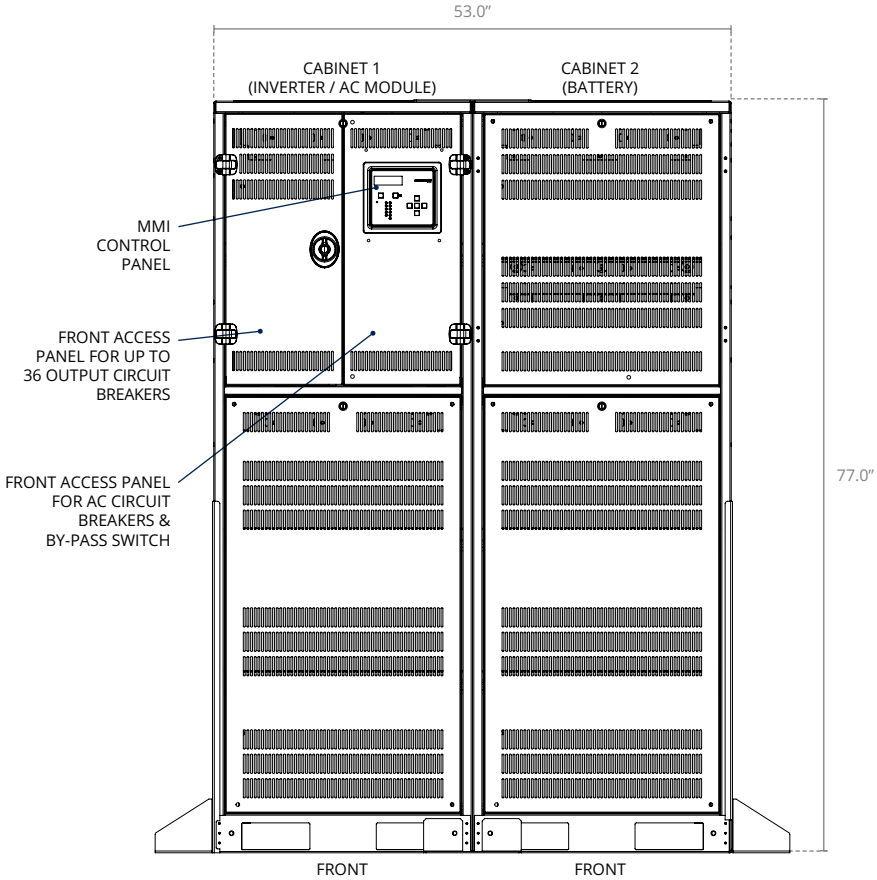

[VIEW SPEC SHEET](#)

WEIGHT				
# of Cabinets	Inverter Cabinet Weight (lbs)	Battery Cabinet Weight (lbs)	Shipping Weight (lbs)	# of Batteries
2	790	2820	3645	20



E3MAX-8500-3P

8,500-33,000 VA Three Phase Modular AC Inverter

2 CABINETS

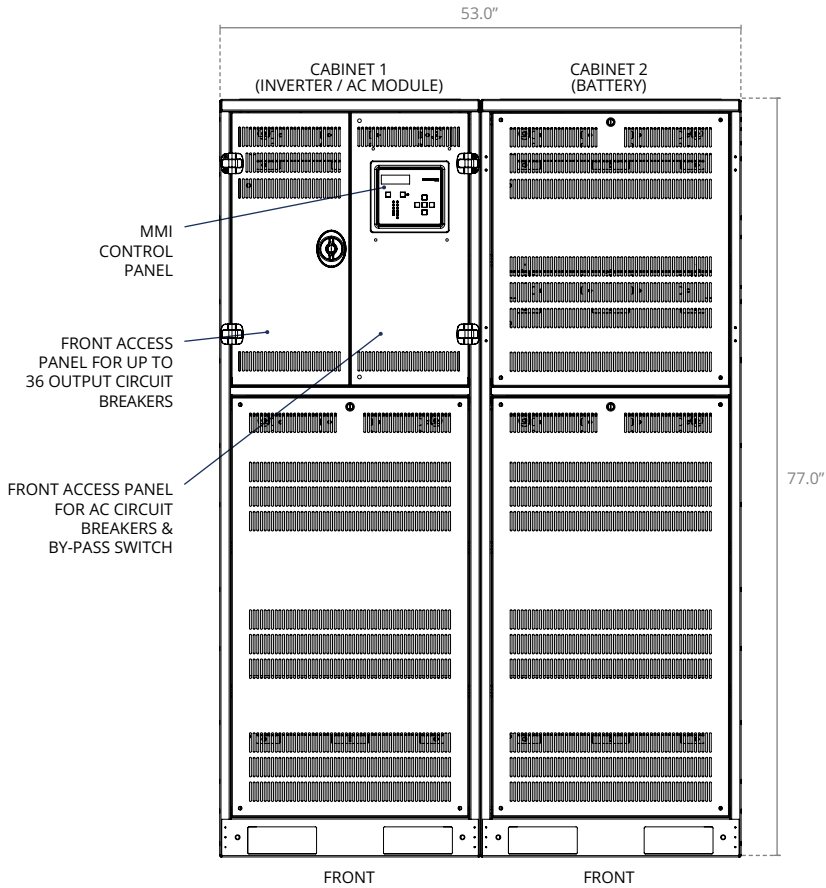

RETURN TO SIZES

[VIEW SPEC SHEET](#)

WEIGHT				
# of Cabinets	Inverter Cabinet Weight (lbs)	Battery Cabinet Weight (lbs)	Shipping Weight (lbs)	# of Batteries
2	760	1600	2355	16

E3MAX-8500-3P

8,500-33,000 VA Three Phase Modular AC Inverter

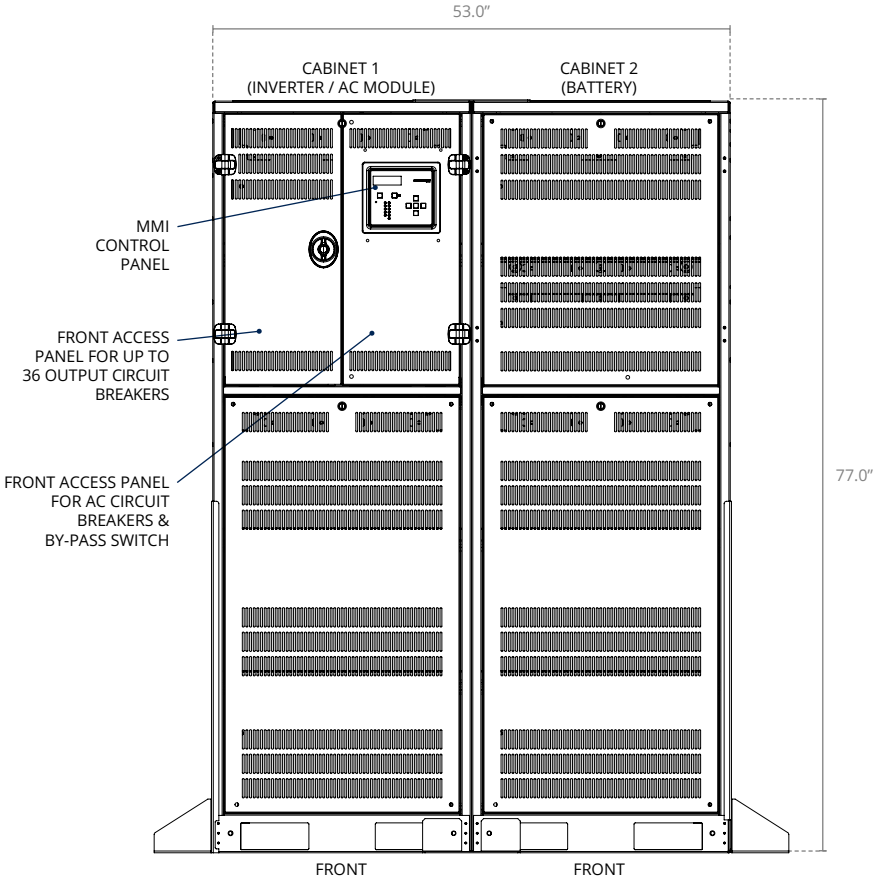

[VIEW SPEC SHEET](#)

WEIGHT				
# of Cabinets	Inverter Cabinet Weight (lbs)	Battery Cabinet Weight (lbs)	Shipping Weight (lbs)	# of Batteries
2	760	1600	2355	16



E3MAX-10500-3P

8,500-33,000 VA Three Phase Modular AC Inverter

2 CABINETS

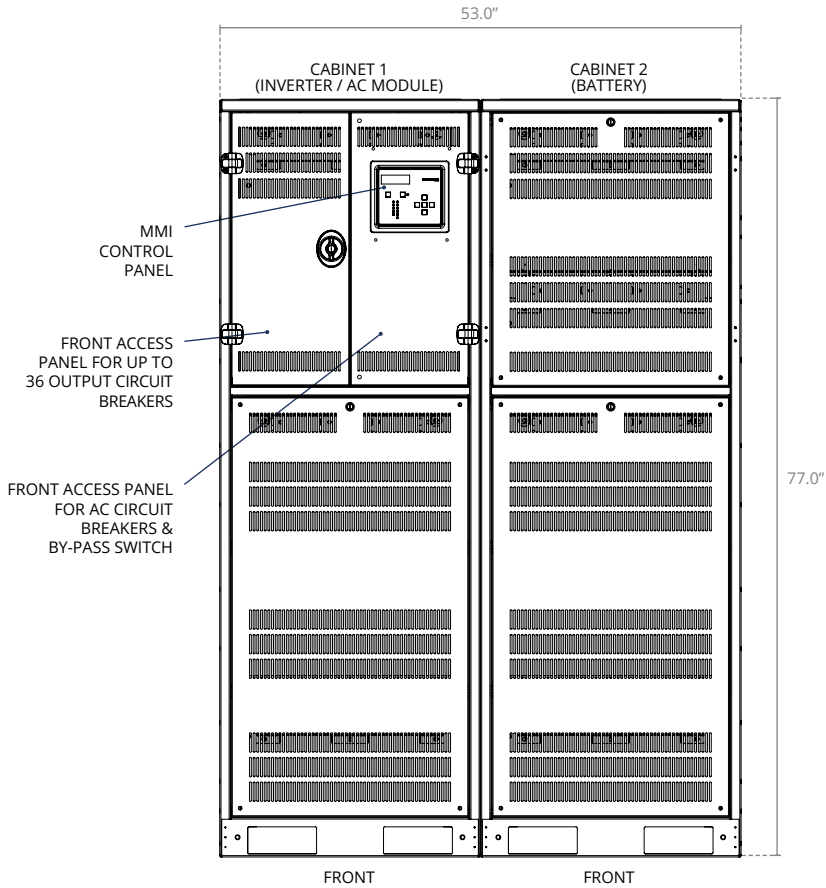

RETURN TO SIZES

[VIEW SPEC SHEET](#)

WEIGHT				
# of Cabinets	Inverter Cabinet Weight (lbs)	Battery Cabinet Weight (lbs)	Shipping Weight (lbs)	# of Batteries
2	760	1900	2695	20

E3MAX-10500-3P

8,500-33,000 VA Three Phase Modular AC Inverter

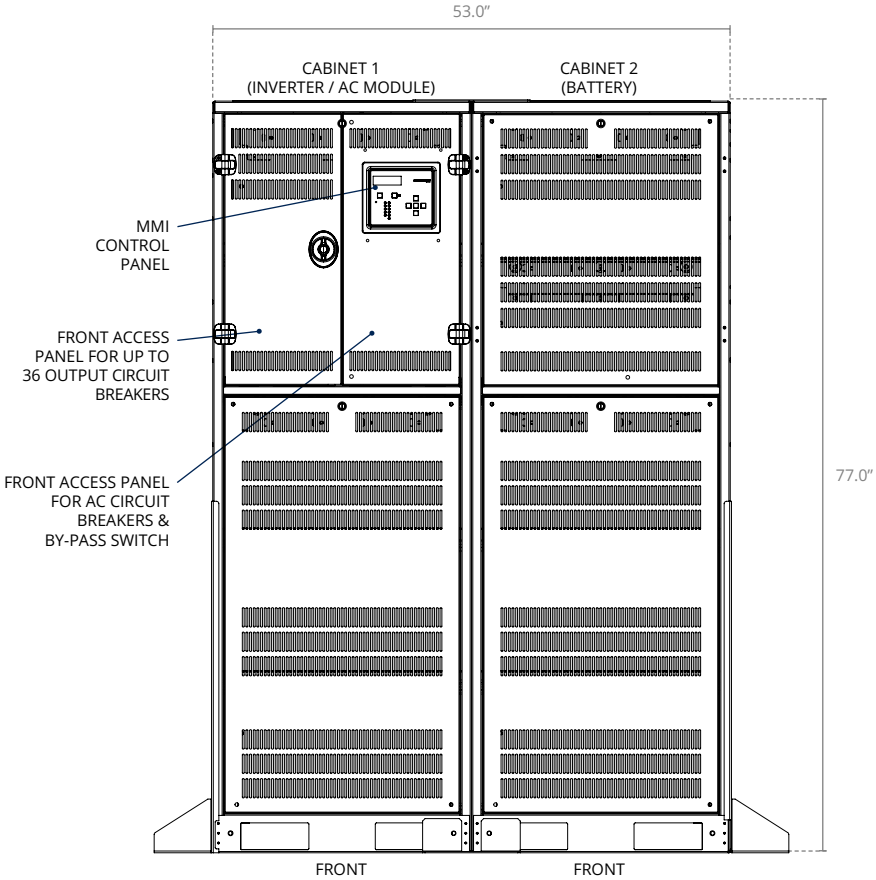

[VIEW SPEC SHEET](#)

WEIGHT				
# of Cabinets	Inverter Cabinet Weight (lbs)	Battery Cabinet Weight (lbs)	Shipping Weight (lbs)	# of Batteries
2	760	1900	2695	20



E3MAX-13300-3P

8,500-33,000 VA Three Phase Modular AC Inverter

2 CABINETS

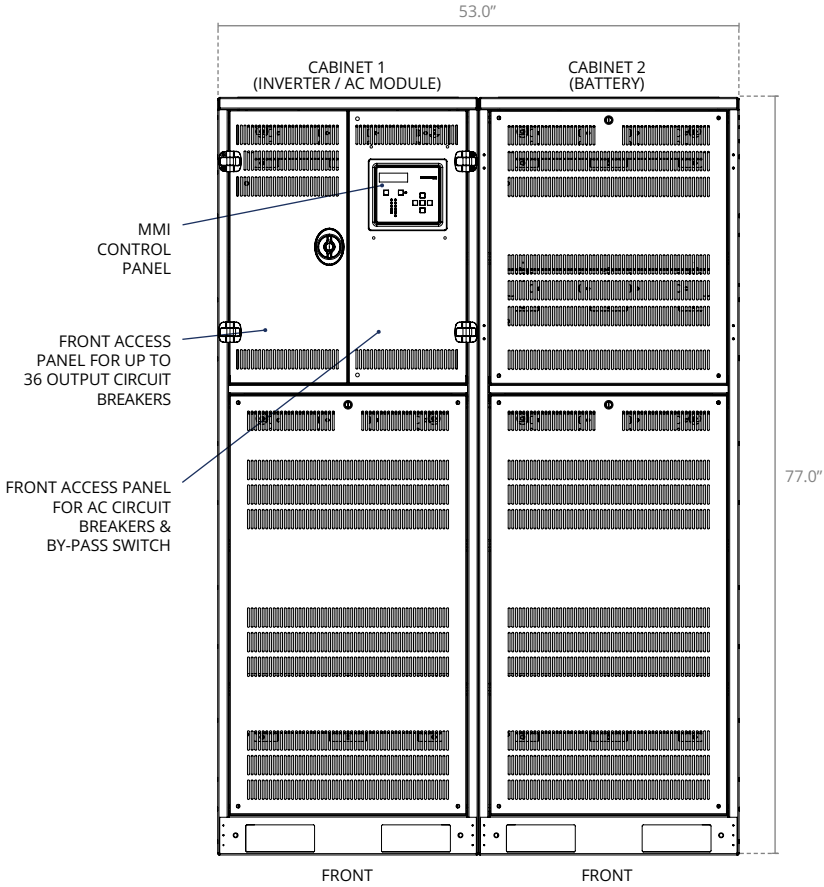

RETURN TO SIZES

VIEW SPEC SHEET

WEIGHT				
# of Cabinets	Inverter Cabinet Weight (lbs)	Battery Cabinet Weight (lbs)	Shipping Weight (lbs)	# of Batteries
2	760	2336	3131	16

E3MAX-13300-3P

8,500-33,000 VA Three Phase Modular AC Inverter

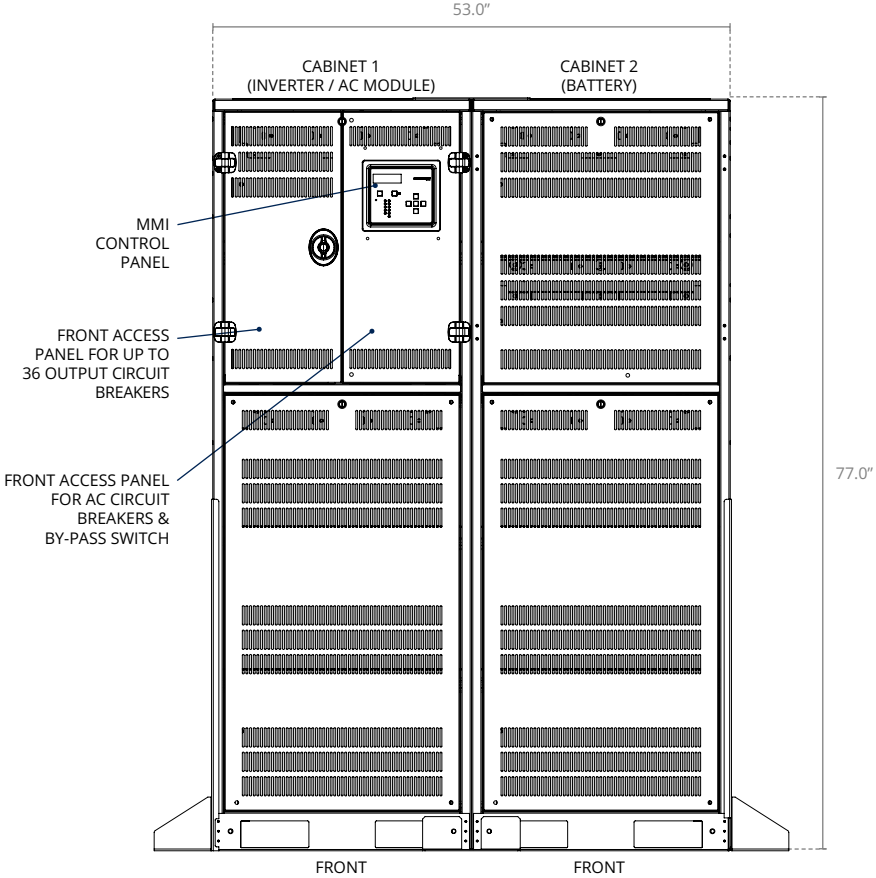

VIEW SPEC SHEET

WEIGHT				
# of Cabinets	Inverter Cabinet Weight (lbs)	Battery Cabinet Weight (lbs)	Shipping Weight (lbs)	# of Batteries
2	760	2336	3131	16



E3MAX-17000-3P

8,500-33,000 VA Three Phase Modular AC Inverter

2 CABINETS

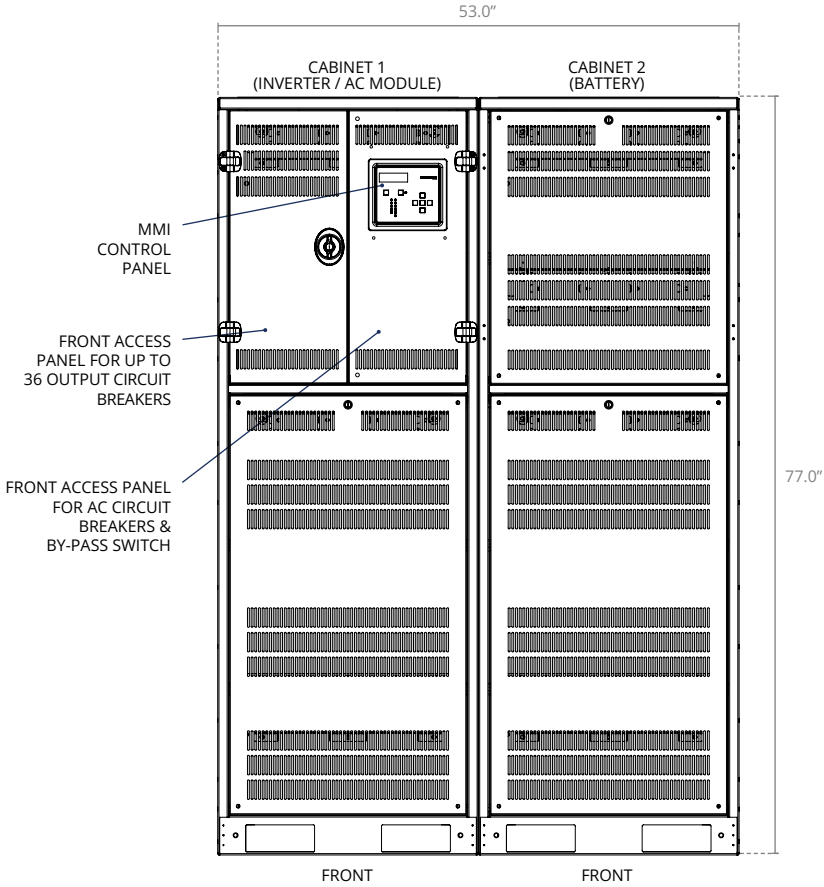

RETURN TO SIZES

VIEW SPEC SHEET

WEIGHT				
# of Cabinets	Inverter Cabinet Weight (lbs)	Battery Cabinet Weight (lbs)	Shipping Weight (lbs)	# of Batteries
2	810	2820	3665	20

E3MAX-17000-3P

8,500-33,000 VA Three Phase Modular AC Inverter

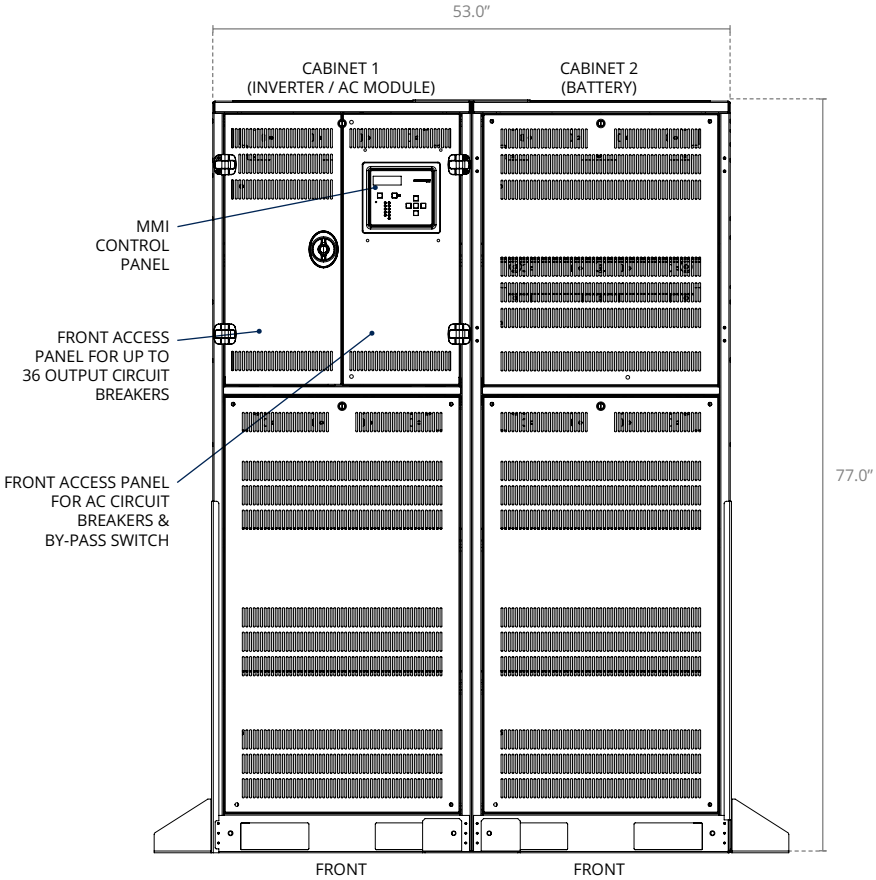

VIEW SPEC SHEET

WEIGHT				
# of Cabinets	Inverter Cabinet Weight (lbs)	Battery Cabinet Weight (lbs)	Shipping Weight (lbs)	# of Batteries
2	810	2820	3665	20



E3MAX-20500-3P

8,500-33,000 VA Three Phase Modular AC Inverter

3 CABINETS

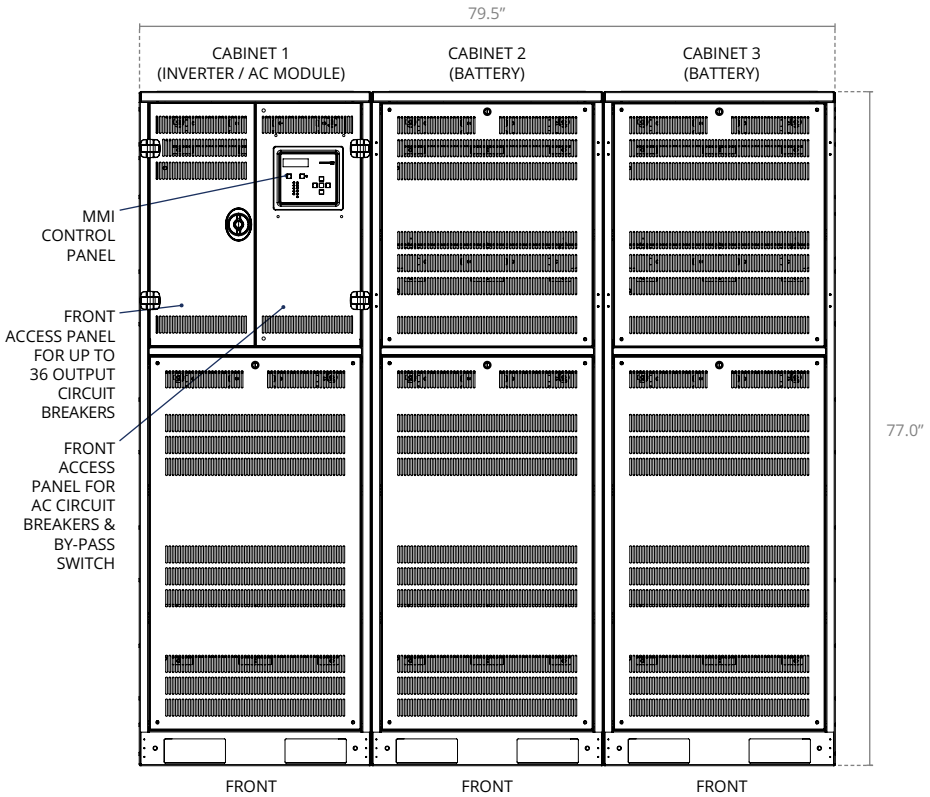

RETURN TO SIZES

[VIEW SPEC SHEET](#)

WEIGHT				
# of Cabinets	Inverter Cabinet Weight (lbs)	Battery Cabinet Weight (lbs)	Shipping Weight (lbs)	# of Batteries
3	810	3800	4680	40

E3MAX-20500-3P

8,500-33,000 VA Three Phase Modular AC Inverter

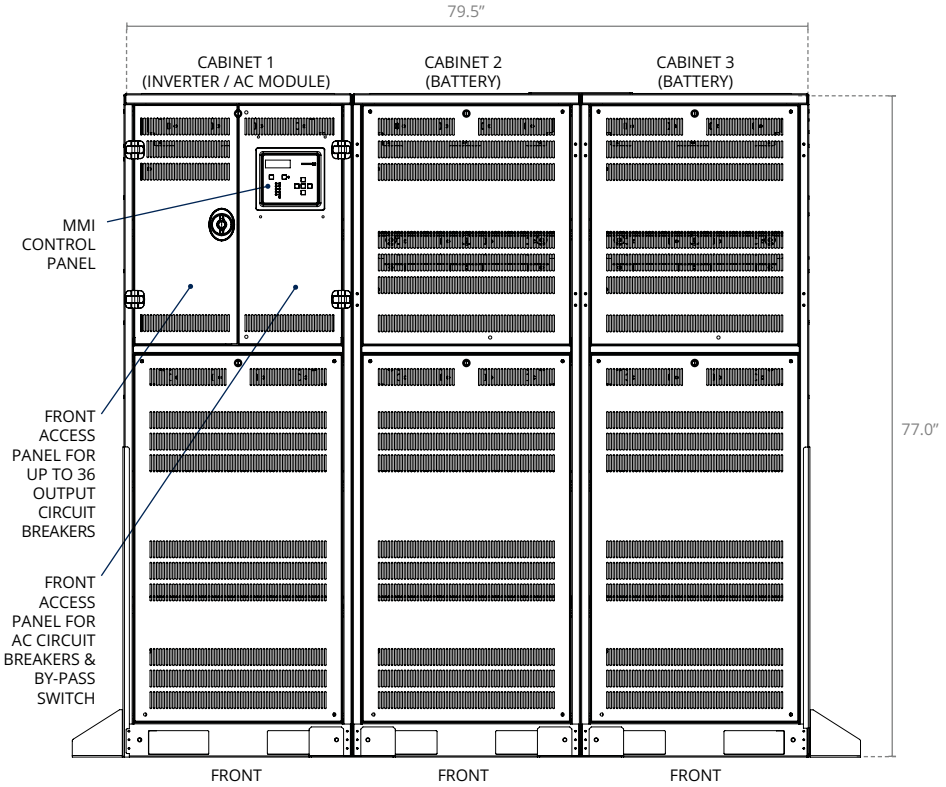

[VIEW SPEC SHEET](#)

WEIGHT				
# of Cabinets	Inverter Cabinet Weight (lbs)	Battery Cabinet Weight (lbs)	Shipping Weight (lbs)	# of Batteries
3	810	3800	4680	40



E3MAX-26500-3P

8,500-33,000 VA Three Phase Modular AC Inverter

3 CABINETS

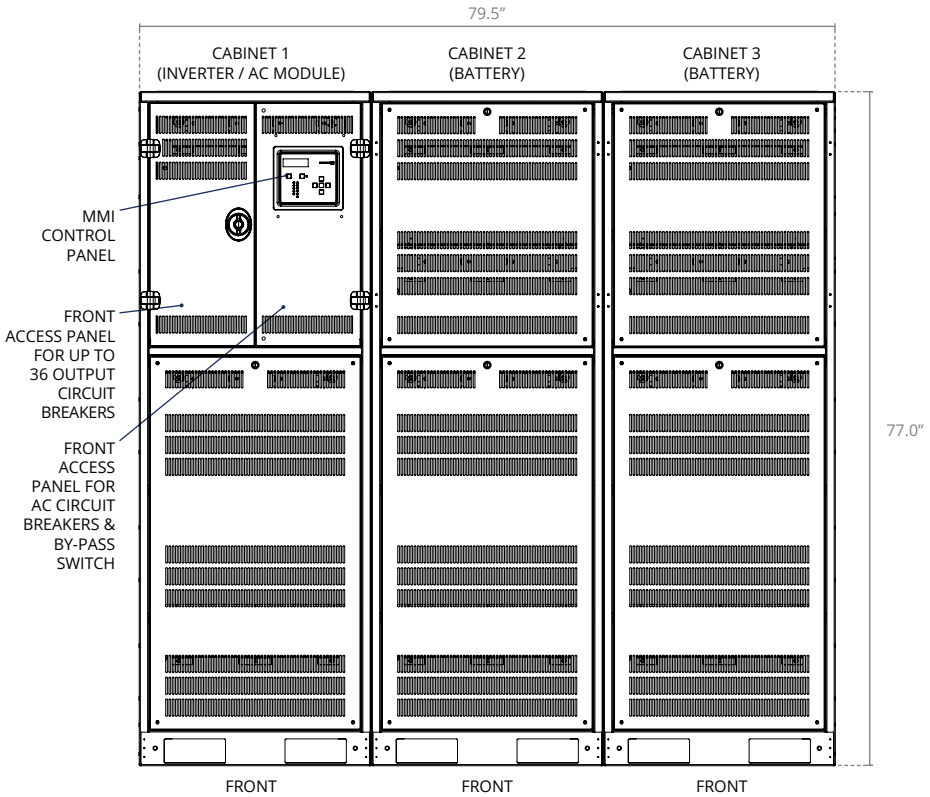

RETURN TO SIZES

[VIEW SPEC SHEET](#)

WEIGHT				
# of Cabinets	Inverter Cabinet Weight (lbs)	Battery Cabinet Weight (lbs)	Shipping Weight (lbs)	# of Batteries
3	890	4672	5632	32

E3MAX-26500-3P

8,500-33,000 VA Three Phase Modular AC Inverter

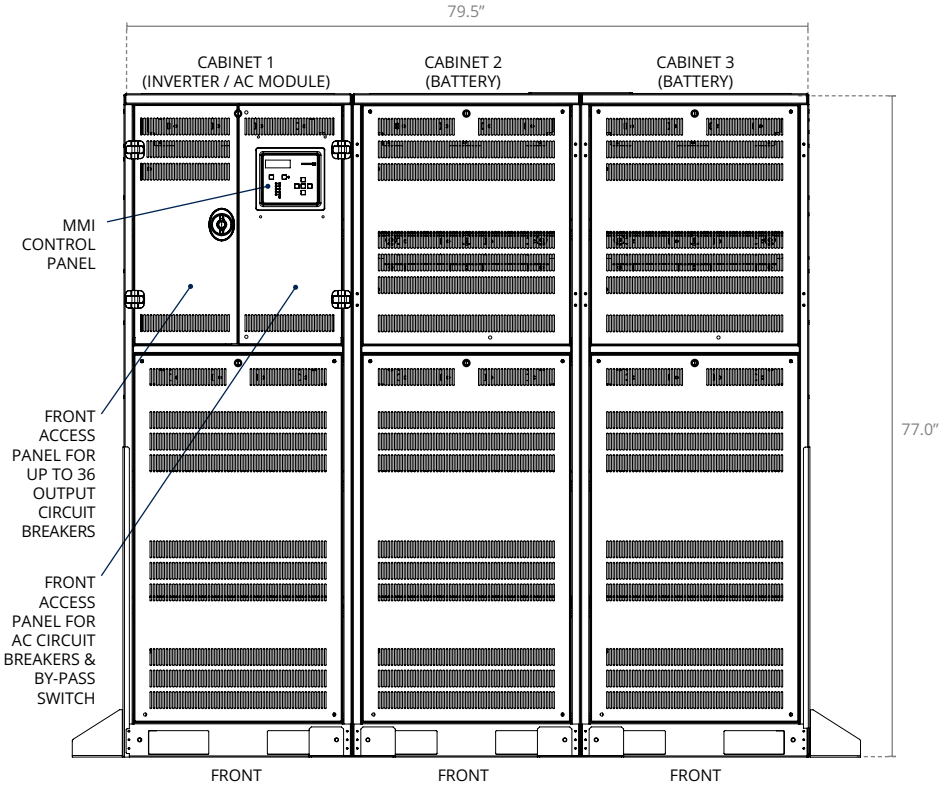

[VIEW SPEC SHEET](#)

WEIGHT				
# of Cabinets	Inverter Cabinet Weight (lbs)	Battery Cabinet Weight (lbs)	Shipping Weight (lbs)	# of Batteries
3	890	4672	5632	32



E3MAX-33000-3P

8,500-33,000 VA Three Phase Modular AC Inverter

3 CABINETS

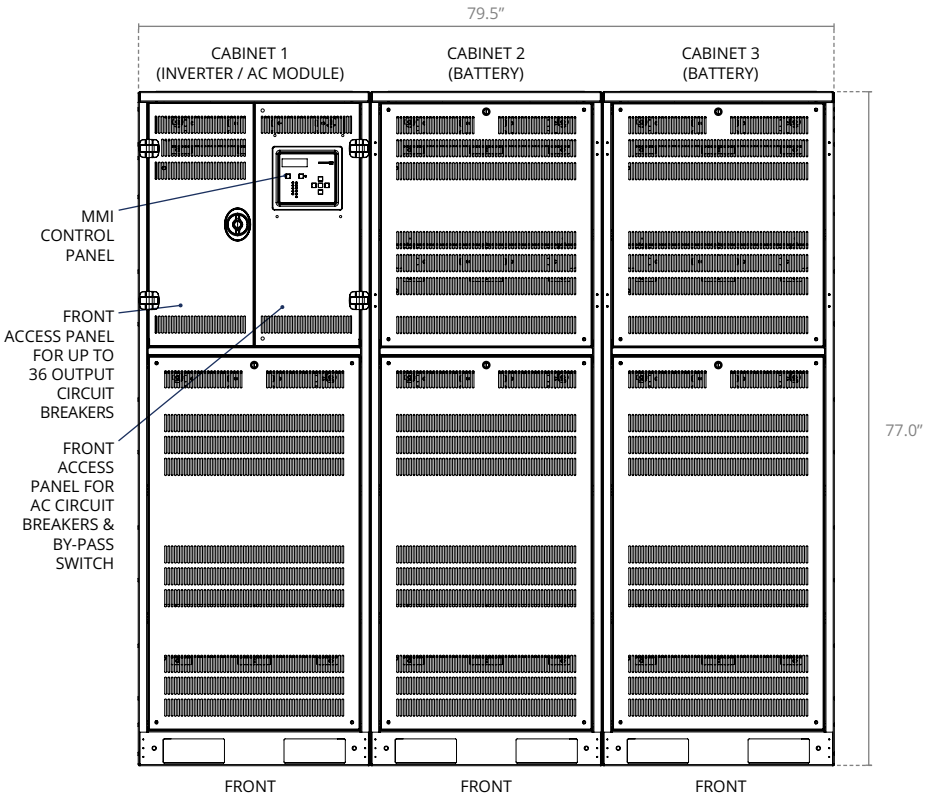

RETURN TO SIZES

[VIEW SPEC SHEET](#)

WEIGHT				
# of Cabinets	Inverter Cabinet Weight (lbs)	Battery Cabinet Weight (lbs)	Shipping Weight (lbs)	# of Batteries
3	890	5640	6600	40

E3MAX-33000-3P

8,500-33,000 VA Three Phase Modular AC Inverter

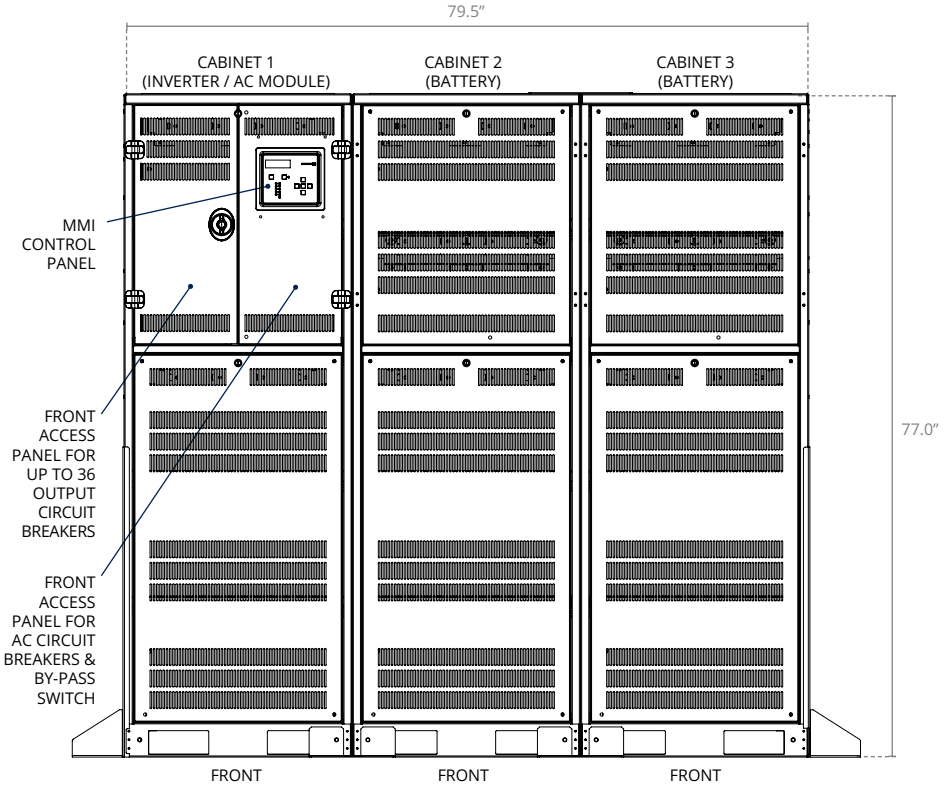

[VIEW SPEC SHEET](#)

WEIGHT				
# of Cabinets	Inverter Cabinet Weight (lbs)	Battery Cabinet Weight (lbs)	Shipping Weight (lbs)	# of Batteries
3	890	5640	6600	40