



# HX

## CLASS 1 DIV 2 LED EXIT SIGN

---

# INSTALLATION AND OPERATING INSTRUCTIONS

## **IMPORTANT SAFEGUARDS**

When using electrical equipment, basic safety precautions should always be followed including the following:

## **READ AND FOLLOW ALL SAFETY INSTRUCTIONS**

1. Make sure the area is NON HAZARDOUS before installing or servicing the unit.
2. Turn off electrical power and disconnect battery before and during installation.
3. Turn off electrical power, disconnect the battery and allow the unit to cool off before opening for maintenance or servicing.
4. Do not install where the marked operating temperatures (T Code) exceed the ignition temperature of the hazardous atmosphere.
5. Keep tightly closed when in operation.
6. Do not mount near gas or electric heaters.
7. Avoid possible shorting with batteries.
8. Equipment should be mounted in locations and at heights where it will not readily be subject to tampering by unauthorized personnel.
9. The use of accessory equipment not authorized by the manufacturer may cause an unsafe condition.
10. Do not use this equipment for other than its intended purpose.
11. Servicing of this equipment should only be performed by qualified service personnel.

## **SAVE THESE INSTRUCTIONS**

31 Waterloo Ave • Berwyn, PA • 19312 U.S.A  
Telephone: (610) 647-8200 • Email: [support@isolite.com](mailto:support@isolite.com)

# WALL MOUNT INSTALLATION - SINGLE FACE

## INSTALLATION WITH MOUNTING BRACKETS

1. The branch circuit supply shall be disconnected prior to installation.
2. Mount the (2) surface mounting brackets provided onto the backplate and secure using the four #7-21x3/8" Flat head screws provided (Figure 2).
3. Place the housing on the required surface. Drill (4) mounting holes on the wall, using the mounting bracket holes as a drilling template. Tap in using a mallet, the four screw anchors into the holes (Figure 2).
4. Remove the (6) plastic caps, (6) screws and (12) O-rings from the EXIT lens and set aside.
5. Separate the lens and EXIT panel assembly (three pieces) from the housing.
6. Feed the AC Supply power leads through the hub assembly into the EXIT Sign enclosure.
7. Refer to the "Wiring Diagrams" section (see page 4) and make electrical connections inside the enclosure using Listed wire connectors suitable for the number and size of the conductors. Use suitable wiring method in accordance with the NEC and CEC local codes for the specific Hazardous Location. Cap off the unused (Red or Black) lead. Ensure that the wires are tucked away neatly in the channel between the interior frame and external enclosure. Complete battery connection for units with batteries.
8. Remove one or both of the directional indicators from the EXIT panel, as needed.
9. Reinstall the lens and EXIT panel assembly using the (6) plastic caps, (6) screws and (12) O-rings previously removed (under step 4) and set aside. Tighten the screws enough to compress the O-rings to ensure a good sealed joint. Be careful to not over-tighten, as that could result in damaging the lens and affect proper sealing of the unit.
10. Mount the Exit sign to the wall surface using the four #1/4-8xl-1/4" pan head mounting screws and previously installed screw anchors.
11. Apply power. For units with battery, allow the unit to charge for 24 hours before testing it in emergency mode.

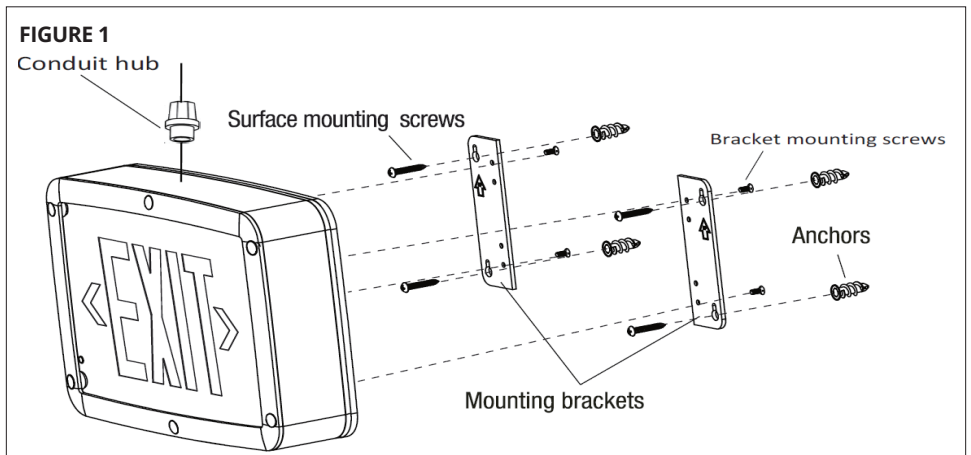

## PENDANT MOUNT INSTALLATION - DOUBLE FACE

1. The branch circuit supply shall be disconnected prior to installation
2. Remove the (6) plastic caps, (6) screws and (12) O-rings from the EXIT lens and set aside.
3. Separate the lens and EXIT panel assembly (three pieces) from the housing.
4. Position and install the conduit (pendant) and feed the AC supply wire through the end of the pendant. Feed the AC Supply pwr leads through the hub assembly into the EXIT sign enclosure.
5. Refer to the "Wiring Diagrams" section (see page 4) and make electrical connections inside the enclosure using Listed wire connectors suitable for the number and size of the conductors. Use suitable wiring method in accordance with the NEC and CEC local codes for the specific Hazardous Location. Cap off the unused (Red or Black) lead. Ensure that the wires are tucked away neatly in the channel between the interior frame and external enclosure. Complete battery connection for units with batteries.
6. Remove one or both of the directional indicators from the EXIT panel, as needed.
7. Reinstall the lens and EXIT panel assembly using the (6) plastic caps, (6) screws and (12) O-rings previously removed (under step 2) and set aside. Tighten the screws enough to compress the O-rings to ensure a good sealed joint. Be careful to not overtighten, as that could result in damaging the lens and affect proper sealing of the unit.
8. Apply power. Allow the unit to charge for 24 hours before testing it in emergency mode.

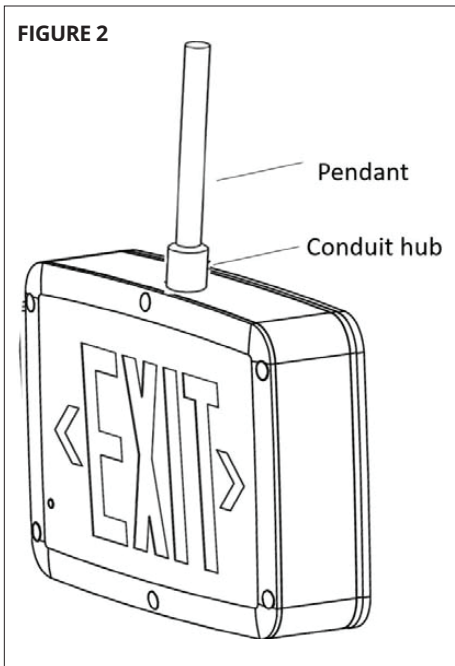

# OPERATION & TESTING

National Electric Code (NEC) and NFPA 101 current Life Safety code requirements require that routine tests need to be performed as listed below:

1. Once every month, the unit needs to be tested for a duration of 30 seconds. Place and hold the magnet near the magnetic switch on the fixture to perform this test (Figure 3).
2. Once every 12 months, a full 90 minute (per UL requirements) test needs to be performed on the unit. Disconnect power to the unit and leave it in the emergency mode. The EXIT section and the lampheads should stay ON for at least 90 minutes. Written records of the testing are to be kept for examination by the authority having jurisdiction.

## LED STATUS INDICATOR KEY & TROUBLESHOOTING

STATUS DISPLAY	MEANING	ACTION
Red	<ol style="list-style-type: none"><li>1. Battery connection is not made.</li><li>2. Battery has been diagnosed as dead or defective after 24 hours of continuous charging with AC power supplied.</li></ol>	<ol style="list-style-type: none"><li>1. Make connection; or if battery is connected, disconnect battery for eight seconds and then reconnect.</li><li>2. Replace the battery.</li></ol>
Green	Battery is connected, AC power has been supplied and fixture is in charging state.	This is the normal state. No action required.
Unlit	AC power has not been supplied or unit is in EM mode.	Supply AC power or wait until utility power is restored

## MAINTENANCE

**CAUTION:** To reduce the risk of ignition of hazardous atmospheres, disconnect the exit sign from the supply circuit. Determine the area is non-hazardous before opening the enclosure and disconnect the battery. Keep tightly closed when in operation. Servicing should be performed only by a qualified service technician. Use only MANUFACTURER supplied replacement parts.

**BATTERY:** The battery supplied requires no maintenance. However, it should be tested periodically and replaced when it no longer operates the connected unit for the duration of a 30 second or 90 minute test.

**FIGURE 3: Magnetic Test - Only for battery version.**

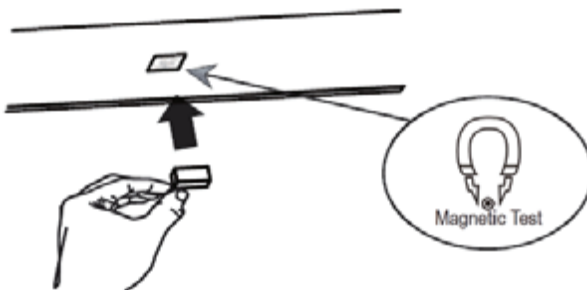

# WIRING DIAGRAMS

**WARNING:** Insulate the unused lead wires, Red (277V) of Black (120V) from the transformer, using Listed wire connectors suitable for the number and size of the conductors.

## BATTERY BACKUP (EM)

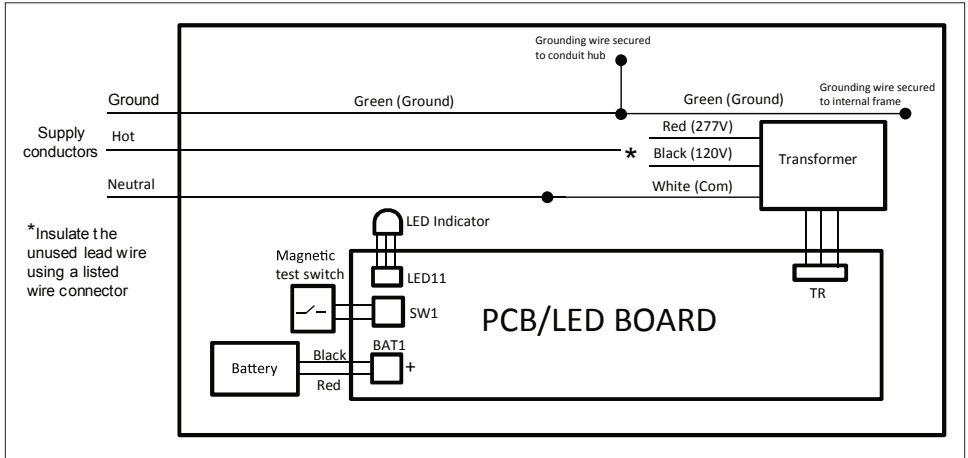

## SELF-DIAGNOSTIC TEST (SD)

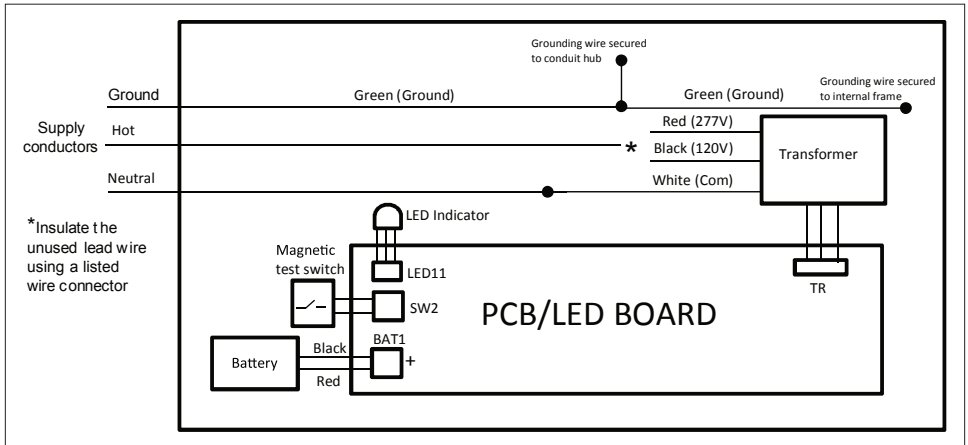

# WIRING DIAGRAMS

CONTINUED

**WARNING:** Insulate the unused lead wires, Red (277V) or Black (120V) from the transformer, using Listed wire connectors suitable for the number and size of the conductors.

## AC ONLY

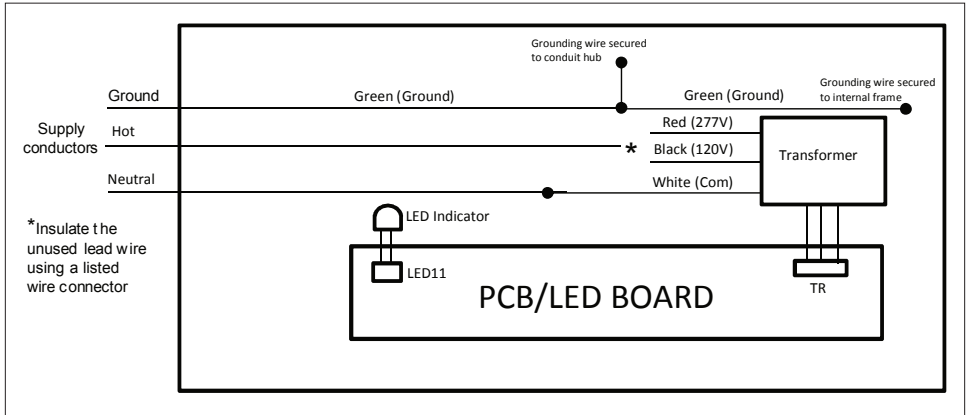

CONTINUE TO NEXT PAGE

# SELF-DIAGNOSTIC TESTING

**INTRODUCTION:** Once the unit is properly installed according to the Installation instructions and AC power is supplied, the EXIT will come ON. The dual-color LED indicator will also come ON, automatically initiating the self-diagnostic test function. The LED indicator points out the current unit status. Refer to “Fault Indication” section for more details. The LED indicator would be OFF when the unit is in Emergency mode.

**SELF-DIAGNOSTIC SERVICE:** The self diagnostic function is factory preset without any field adjustment. The automatic self diagnostic feature serves the following tests:

- On-line real time monitoring of battery, lamps and LED(s): Identifies battery charging, disconnection and failure along with LED failures.
- Self testing and a 30 second discharge once every 30 days (conforming to NFPA code requirements), after AC power has been supplied for a minimum of 24 hours.
- Self testing and a 30 minute discharge once every 180 days, after AC power has been supplied for a minimum of 24 hours.
- Self testing and a 90 minute discharge once every 365 days, after AC power has been supplied for a minimum of 24 hours.

## FAULT INDICATION

LED DISPLAY	STATUS DISPLAY
Steady Green	Unit is in normal mode
Steady Red	Battery disconnected
Alternate Red & Green	Battery recharge
Flashing Red	Battery recharge failure <sup>1</sup>
Blinking Red (x2)	Battery failure <sup>2</sup>
Blinking Red (x3)	LED failure

### NOTES

- A battery recharge failure will come up if the battery is NOT able to recharge within the 24 hrs charging time.
- A battery failure will come up if the battery is NOT able to operate the LED strip for the period of a discharge test.

**MANUAL TESTING:** This unit can also be manually tested using the magnetic test switch. Place the magnet (provided) on the unit (near the section marked as “Magnetic Test”) and pull away (at least 3 cm from the unit). This will force the unit to run a 30-second discharge test. Test can be interrupted by placing the magnet again on the unit and pulling it away. To reset the unit, place and hold the magnet for 6 seconds and then pull away.

**OPERATION:** During an electrical power failure, the LED strip will transfer into Emergency mode and stay LIT for a minimum of 90 minutes. To test this unit, the battery needs to be charged initially for 24 hours before using the magnetic test switch (to do manual test). In the test mode, the LED strip will transfer into a SIMULATED Emergency mode with the LED indicator FLASHING Green. The LED strip will continue to stay on after 30 seconds.

## SAVE THESE INSTRUCTIONS

31 Waterloo Ave • Berwyn, PA • 19312 U.S.A

Telephone: (610) 647-8200 • Email: support@isolite.com