



## HR

### CLASS 1 DIV 2 LED REMOTE HEAD

---

# INSTALLATION AND OPERATING INSTRUCTIONS

## IMPORTANT SAFEGUARDS

When using electrical equipment, basic safety precautions should always be followed including the following:

## READ AND FOLLOW ALL SAFETY INSTRUCTIONS

1. Make sure the area is NON-HAZARDOUS before installing or servicing the unit.
2. Turn off electrical power and disconnect battery before and during installation.
3. Turn off electrical power, disconnect the battery and allow the unit to cool off before opening for maintenance or servicing.
4. Do not install where the marked operating temperatures (T Code) exceed the ignition temperature of the hazardous atmosphere.
5. Keep tightly closed when in operation.
6. Do not mount near gas or electric heaters.
7. Avoid possible shorting with batteries.
8. Equipment should be mounted in locations and at heights where it will not readily be subject to tampering by unauthorized personnel.
9. The use of accessory equipment not authorized by the manufacturer may cause an unsafe condition.
10. Do not use this equipment for other than its intended purpose.
11. Servicing of this equipment should only be performed by qualified service personnel.

## SAVE THESE INSTRUCTIONS

31 Waterloo Ave • Berwyn, PA • 19312 U.S.A  
Telephone: (610) 647-8200 • Email: [support@isolite.com](mailto:support@isolite.com)

# WALL MOUNT INSTALLATION

## INSTALLATION WITH MOUNTING BRACKETS

1. The branch circuit supply shall be disconnected prior to installation.
2. Mount the (2) surface mounting brackets provided onto the backplate/back housing and secure using the four #7-21x3/8" flat head screws provided (Figure 2).
3. Place the housing on the required surface. Drill (4) mounting holes on the wall, using the mounting bracket holes as a drilling template. Tap in using a mallet, the four screw anchors into the holes (Figure 1).
4. Remove the (4) plastic caps and loosen the (4) lens screws until the lens is detachable from the unit housing. Note: Do not detach the (4) screws and (8) O-rings from the lens' mounting holes.
5. Separate the lens from the fixture. Pull out the internal enclosure base.
6. Feed the AC Supply power leads through the hub assembly into the back housing.
7. Refer to the "Wiring Diagrams" section (see pages 4-6) and make electrical connections inside the enclosure using Listed wire connectors suitable for the number and size of the conductors. Use suitable wiring method in accordance with the NEC and CEC local codes for the specific Hazardous Location. Cap off the unused (Red or Black) lead. Ensure that the wires are tucked away neatly in the enclosure. Complete battery connection.
8. If remote lamps are to be connected to the Unit Equipment, refer to the "Wiring Diagrams" section (see pages 4-6) and make electrical connections inside the enclosure using Listed wire connectors suitable for the number and size of the conductors. Use suitable wiring method in accordance with the NEC and CEC local codes for the specific Hazardous location.
9. Reinstall the internal enclosure base and lens, previously pulled out in Step 5, in the same order.
10. Secure the lens to the back housing, using the (4) lens screws , (8) O-rings and (4) plastic caps. Tighten the screws enough to compress the O-rings to ensure a good sealed joint. Be careful to not overtighten, as that could result in damaging the lens and affect proper sealing of the unit.
11. Mount the fixture to the wall surface using the four #1/4-8x1-1/4" pan head mounting screws and previously installed screw anchors.
12. Apply power. Allow the unit to charge for 24 hours before testing it in emergency mode.

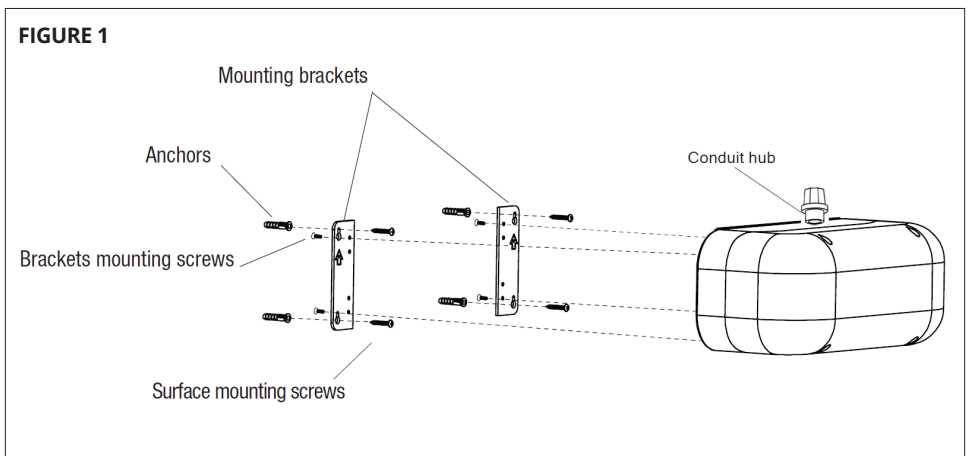

# PENDANT MOUNT INSTALLATION

1. The branch circuit supply shall be disconnected prior to installation.
2. Remove the (4) plastic caps and loosen the (4) lens screws until the lens is detachable from the unit housing.  
**Note:** Do not detach the (4) screws and (8) O-rings from the lens' mounting holes.
3. Separate the lens from the fixture. Pull out the internal enclosure base.
4. Position and install the conduit (pendant) and feed the AC supply wires through the end of the pendant.
5. Feed the AC Supply power leads through the hub assembly into the back housing.
6. Refer to the "Wiring Diagrams" section (see pages 4-6) and make electrical connections inside the enclosure using Listed wire connectors suitable for the number and size of the conductors. Use suitable wiring method in accordance with the NEC and CEC local codes for the specific Hazardous Location. Cap off the unused (Red or Black) lead. Ensure that the wires are tucked away neatly in the enclosure. Complete battery connection.
7. If remote lamps are to be connected to the Unit Equipment, refer to the "Wiring Diagrams" section (see pages 4- 6) and make electrical connections inside the enclosure using Listed wire connectors suitable for the number and size of the conductors. Use suitable wiring method in accordance with the NEC and CEC local codes for the specific Hazardous location.
8. Reinstall the internal enclosure base and lens, previously pulled out in Step 3, in the same order.
9. Secure the lens to the back housing, using the (4) lens screws , (8) O-rings and (4) plastic caps. Tighten the screws enough to compress the O-rings to ensure a good sealed joint. Be careful to not overtighten, as that could result in damaging the lens and affect proper sealing of the unit.
10. Apply power. Allow the unit to charge for 24 hours before testing it in emergency mode.

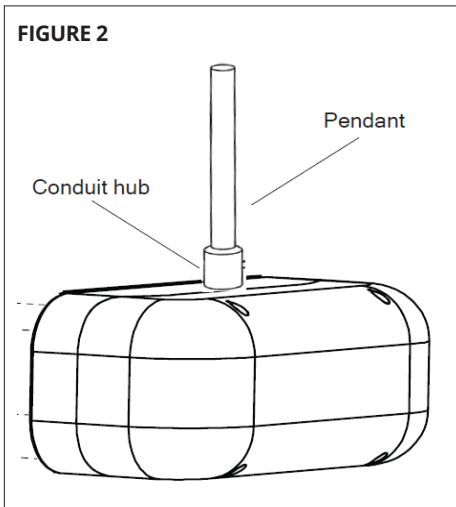

# OPERATION & TESTING

National Electric Code (NEC) and NFPA 101 current Life Safety code requirements require that routine tests need to be performed as listed below:

1. Once every month, the unit needs to be tested for a duration of 30 seconds. Place and hold the magnet near the magnetic switch on the fixture to perform this test (Figure 3).
2. Once every 12 months, a full 90 minute (per UL requirements) test needs to be performed on the unit. Disconnect power to the unit and leave it in the emergency mode. The EXIT section and the lampheads should stay ON for at least 90 minutes. Written records of the testing are to be kept for examination by the authority having jurisdiction.

## LED STATUS INDICATOR KEY & TROUBLESHOOTING

STATUS DISPLAY	MEANING	ACTION
Red	<ol style="list-style-type: none"><li>1. Battery connection is not made.</li><li>2. Battery has been diagnosed as dead or defective after 24 hours of continuous charging with AC power supplied.</li></ol>	<ol style="list-style-type: none"><li>1. Make connection; or if battery is connected, disconnect battery for eight seconds and then reconnect.</li><li>2. Replace the battery.</li></ol>
Green	Battery is connected, AC power has been supplied and fixture is in charging state.	This is the normal state. No action required.
Unlit	AC power has not been supplied or unit is in EM mode.	Supply AC power or wait until utility power is restored

## MAINTENANCE

**CAUTION:** To reduce the risk of ignition of hazardous atmospheres, disconnect the exit sign from the supply circuit. Determine the area is non-hazardous before opening the enclosure and disconnect the battery. Keep tightly closed when in operation. Servicing should be performed only by a qualified service technician. Use only MANUFACTURER supplied replacement parts.

**BATTERY:** The battery supplied requires no maintenance. However, it should be tested periodically and replaced when it no longer operates the connected unit for the duration of a 30 second or 90 minute test.

FIGURE 3

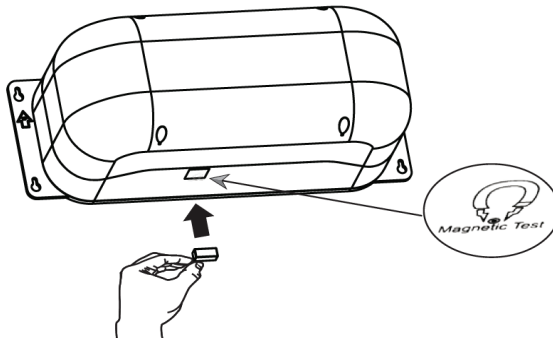

# FIELD WIRING CONNECTIONS & WIRING DIAGRAMS

Refer to Wiring diagrams A/B for standard models and C/D for cold temperature (HX) models

The field wire connections are to be made as follows:

1. The Unit Equipment is provided with color coded field lead wires exiting the single conduit hub opening, as indicated in the table below.
2. Connect the matching color leads together from the Unit Equipment and the field supply wires. Make all electrical supply connections inside the Unit Equipment housing using Listed wired connectors suitable for the number and size of the conductors.
3. Cap off the unused lead wires (Black – 120 Vac Power) or (Red – 277 Vac Power) using Listed wire connectors suitable for the number and size of the conductors.
4. For remote/external load circuit connections, feed the yellow and blue lead wires from the remote/external load through the conduit hub into the fixture housing. Use wire rated to a minimum of 900C. Remote/external load wires must be insulated to the maximum voltage rating.
5. Connect the yellow and blue leads from the remote/external load to the yellow and blue leads identified as "DC OUTPUT 6V" or "DC OUTPUT 12V" within the fixture, using Listed wire connectors suitable for the number and size of conductors. Refer to Figure 4 below.
6. If no remote lamps are being connected, then insulate the remote/external load lead ends inside the fixture with Listed wire connectors.

LEAD WIRE COLOR	FUNCTION/IDENTIFICATION	NUMBER OF WIRES	
		WITHOUT -HX OPTION	WITH -HX OPTION
Green	Ground	1	1
White	Neutral	1	2
Black	120 VAC Power	1	2
Red	277 VAC Power	1	2

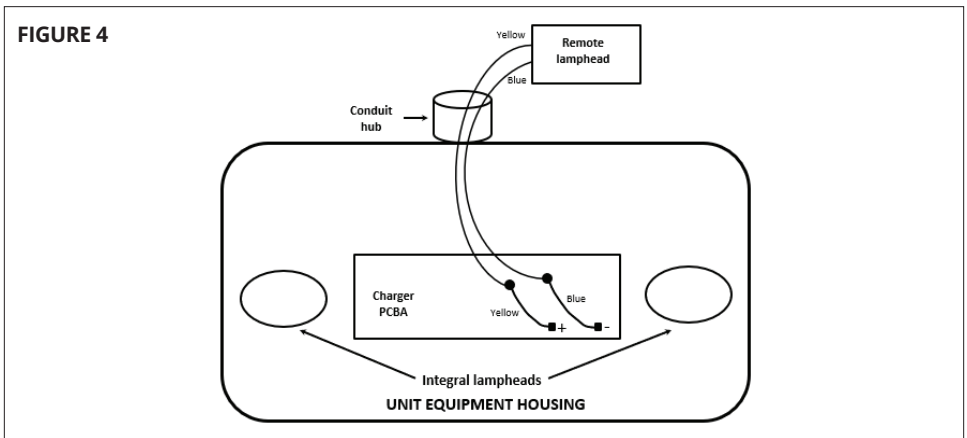

## SAVE THESE INSTRUCTIONS

31 Waterloo Ave • Berwyn, PA • 19312 U.S.A  
 Telephone: (610) 647-8200 • Email: support@isolite.com