INSTRUCTIONS

IMPORTANT SAFEGUARDS

When using electrical equipment, basic safety precautions should always be followed including the following:

1. **READ AND FOLLOW ALL SAFETY INSTRUCTIONS**
2. Disconnect power before performing work on electrical equipment.
3. Do not let power cords touch hot surfaces and do not mount near gas or electric heaters.
4. Use caution when servicing batteries. Battery acid can cause burns to skin and eyes. If acid is spilled on skin or eyes, flush with fresh water and contact a physician immediately.
5. Equipment should be mounted in locations and at heights where unauthorized personnel will not readily subject it to tampering.
6. The use of accessory equipment not recommended by Isolite Inc., may cause an unsafe condition, and will void the unit's warranty.
7. Do not use this equipment for other than its intended purpose.
8. Servicing of this equipment should be performed by qualified service personnel.
9. **SAVE THESE INSTRUCTIONS!**

INSTALLATION

WALL MOUNT - SINGLE FACE (See Figure 1):

1. Extend unswitched 24 hour AC supply of rated voltage to junction box (supplied by others). Leave at least eight (8) inches of slack wire. The circuit should not be energized at this time.
2. Loosen the four (4) plastic screws (one in each corner) on the front cover / faceplate and then remove the cover (Figure 1).
3. Fasten the four (4) mounting feet to the back of the enclosure using the supplied screws; one on each corner. (Figure 2)
4. Mount the exit securely in place using the four (4) mounting feet holes (one located in each corner - screws not supplied).
5. Drill appropriate sized hole(s) in the enclosure for electrical entrance.
Use a rated watertight connector/conduit hub(s) to connect AC supply to the enclosure.
6. Pass power wires through previously drilled holes(s) and connector(s).
7. Connect supply per diagram provided (Figure 3). **Insulate unused wire! CAUTION! - Failure to insulate unused wire may result in a shock hazard or unsafe condition as well as equipment failure.**
8. Connect remote load wires (if any) to lamp output terminals. Route all wires and secure them in place.
9. Uncoil the wire lead(s) from the Positive battery terminal (+) and connect to the positive terminal connector on the circuit board (Figure 3).
10. Route wires and secure them in place.
11. Remove the appropriate chevrons from the stencil inside the cover. Peel the backing off the double sided tape on the coloured fibre, then carefully align and stick the fibre to the stencil.
12. Replace the cover and tighten the four (4) plastic screws.
13. Turn on the voltage supply.

CEILING/END MOUNT - SINGLE OR DOUBLE FACE:

1. Loosen the four (4) plastic screws (one in each corner) on the front cover / faceplate and then remove the faceplate. (Figure 1)
2. Remove the canopy / nipple assembly by unscrewing the nut from the inside of the cabinet. (Figure 4)
3. Feed the supply wires through the threaded nipple - leave at least 8 inches of slack wire.
4. Securely mount the canopy in place (mounting holes fit standard electrical boxes)
5. Mount the exit sign on the installed canopy, passing the threaded nipple and slack wires through the drilled hole.
6. Secure the exit sign to the threaded nipple using the supplied lock-washer and nut. (Figure 4)
7. Connect voltage supply per diagram supplied (Figure 3). **Insulate unused wire! CAUTION! - Failure to insulate unused wire may result in a shock hazard or unsafe condition as well as equipment failure.**
8. Connect remote load wires (if any) to lamp output terminals. Route all wires and secure them in place.
9. Uncoil the wire lead(s) from the Positive battery terminal (+) and connect to the positive terminal connector on the circuit board (Figure 3).
10. Route wires and secure them in place.
11. Remove the appropriate chevrons from the stencil inside the cover. Peel the backing off the double sided tape on the coloured fibre, then carefully align and stick the fibre to the stencil.
12. Replace the cover and tighten the four (4) plastic screws.
13. Turn on the voltage supply.

Figure 1

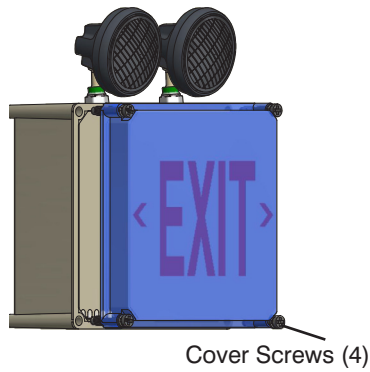

Figure 2

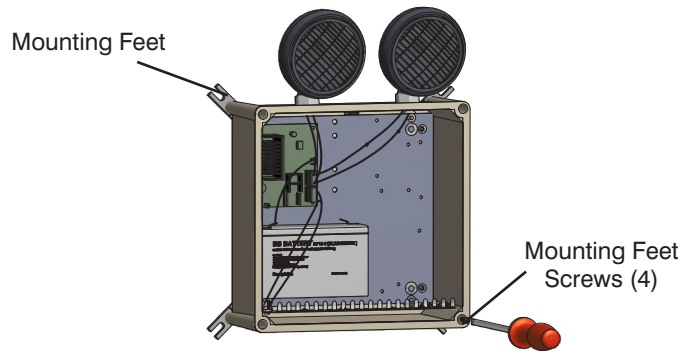

Figure 3

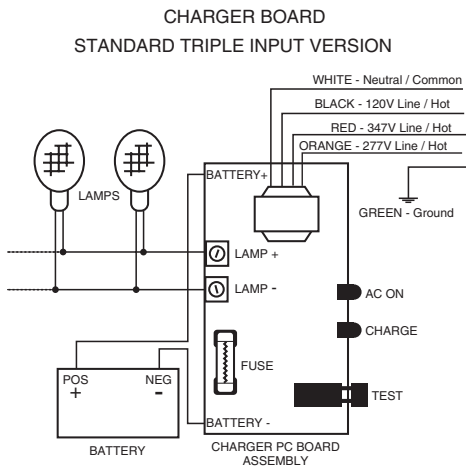
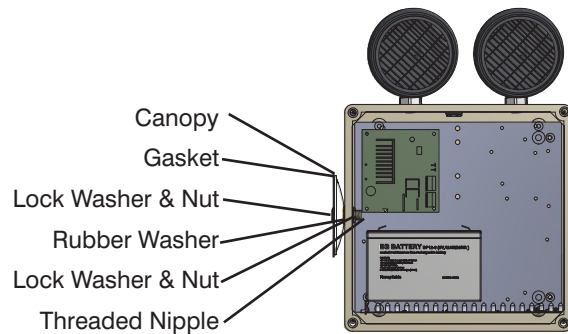

Figure 4



MAINTENANCE

1. Code requires that the equipment be tested every 30 days, and that written records be maintained. Further, the equipment is to be tested once a year for the required duration. The equipment is to be replaced or repaired whenever it fails to operate as intended during the duration test. Written records of test results and any repairs made must be maintained for presentation to the authority having jurisdiction. Isolite Inc. strongly recommends compliance with all Code requirements.
2. The lamps listed herein when used according to the instructions with this unit are in accordance with the requirements of CSA Standard C22.2, No. 141 – Unit Equipment for Emergency Lighting.
3. Clean faceplates/lenses on a regular basis.

CAUTION: Always turn off AC power before servicing. The servicing of any parts, should be performed by qualified service personnel. The use of replacement parts not furnished by Isolite Inc. may cause equipment failure and will void the warranty.

TROUBLESHOOTING

EXIT SIGN DOES NOT COME ON AT ALL

1. Check AC supply and all AC connections - be sure exit has 24 hour AC supply (unswitched).
2. Check supply voltage and AC connections. The AC supply must be at least 80% of nominal (96V on a 120V line) for equipment to function normally. At lower voltages the LEDs may begin to glow dimly until the source voltage drops below the full “turn-on/off” point.
NOTE: This condition may also be caused by incorrectly connecting a voltage supply line to the transformer lead.
3. If AC supply is OK; replace LED circuit board assembly.

SAVE THESE INSTRUCTIONS