



# **Genie Series**

## **FULLY RECESSED EMERGENCY LIGHT**

### **INSTALLATION AND OPERATING INSTRUCTIONS**

#### **IMPORTANT SAFEGUARDS**

When using electrical equipment, basic safety precautions should always be followed including the following:

#### **READ AND FOLLOW ALL SAFETY INSTRUCTIONS**

1. Before wiring to power supply, disconnect power at fuse or circuit breaker.
2. Disconnect A.C. power before servicing.
3. Refer to wiring instructions sheet for proper connections.
4. Consult your local building code for approved wiring and installation.
5. Do not use outdoors.
6. Do not mount near gas or electric heaters.
7. Equipment should be mounted in locations and at heights where it will not readily be subject to tampering by unauthorized personnel.
8. The use of accessory equipment not recommended by the manufacturer may cause an unsafe condition.
9. Caution: Halogen cycle lamps are used in this equipment. To avoid shattering: Do not operate lamp in excess of rated voltage, protect lamp against abrasion and scratches and against liquids when lamp is operating, dispose of lamp with care.
10. Halogen cycle lamps operate at high temperatures. Do not store or place flammable materials near lamp.
11. Do not use this equipment for other than intended use.
12. Servicing of this equipment should be performed by qualified service personnel.

#### **SAVE THESE INSTRUCTIONS**

31 Waterloo Avenue - Berwyn - PA 19312 U.S.A.  
Telephone: (610) 647-8200 Fax: (610) 296-8952  
[www.isolite.com](http://www.isolite.com)

# BACKBOX INSTALLATION

**DO NOT INSTALL SHELF INTO BACKBOX UNTIL WIRING IS COMPLETE**

## MOUNTING BRACKET

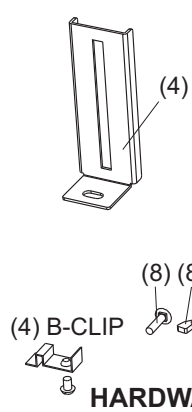

## BAR HANGERS

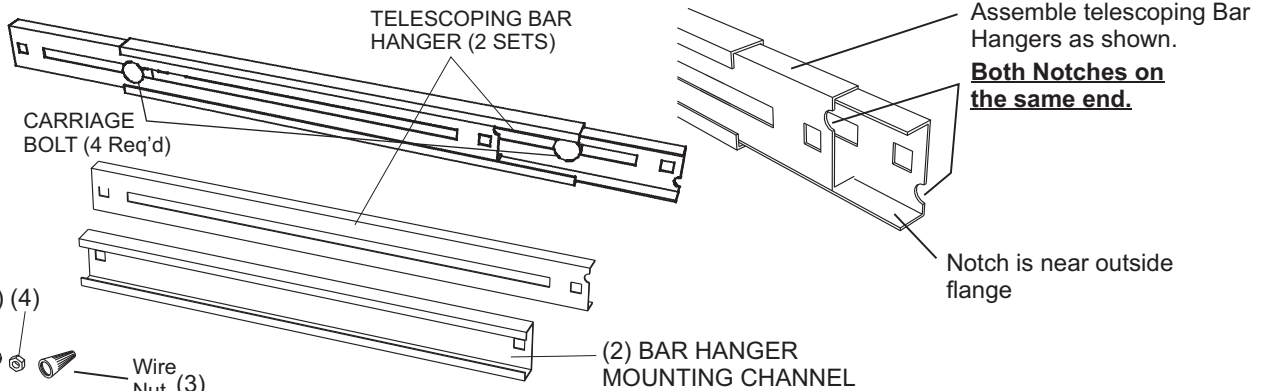

## MAXIMUM MOUNTING HEIGHTS

21 feet when used with 12 Watt lamps  
 52 feet when used with 20 Watt lamps  
 60 feet when used with 35 Watt or 50 Watt or 75 Watt lamps

## ROUGH-IN CEILING MOUNT

Bar Hangers are adjustable from 13-1/2" to 30"

**SUPPORTING MEMBERS MUST BE ABLE TO SUPPORT A LOAD OF AT LEAST 50 LBS.**

Attach Bar Hangers to backbox sides or top/bottom using carriage bolts and wing nuts supplied. Wing nuts should be inside backbox if height adjustment will be necessary from below ceiling. If access for height adjustment will be available from above, wing nuts should be outside backbox.

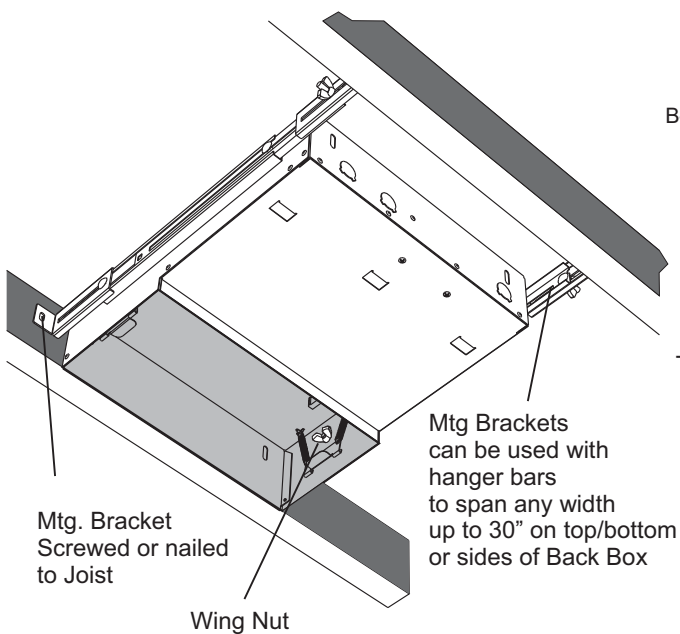

## WOOD JOIST

Attach Mounting Brackets directly to Back Box or if additional length required, to Bar Hangers as shown and adjust Bar Hangers to fit against joists. Fasten to joists with nails or screws supplied by others.

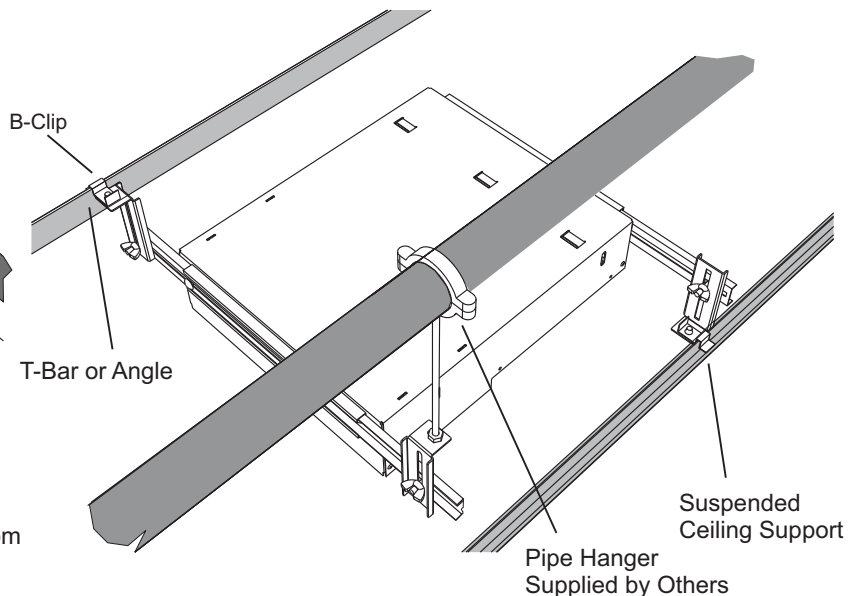

## SUSPENDED CEILINGS

Attach Mounting Brackets and B-clips to Bar Hangers as shown and fasten securely to T-bars, angles, or pipe hangers.

# ROUGH-IN WALL MOUNT

Attach Bar Hangers to backbox top and bottom using carriage bolts and wing nuts supplied. Wing nuts should be inside backbox.

Align backbox so lamphead opening is flush, or slightly behind inner surface of wall material.

## WOOD STUDS:

Fasten Mounting Brackets to ends of Bar Hangers as shown and adjust to fit against studs. Secure with nails or screws supplied by others.

## METAL STUDS:

Installation is the same as for wood studs except that sheet metal screws (supplied by others) should be used to fasten the hanger brackets to the studs. These screws should have a minimum pullout rating of 50 pounds.

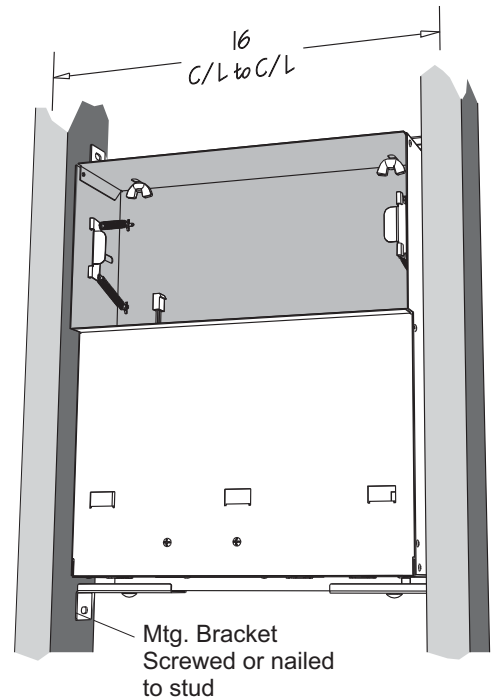

# CLOSE-IN CEILING OR WALL MOUNT

## DRY WALL:

Cutout hole in ceiling material should be 13-1/2" by 6-3/4". Align backbox so lamphead opening is flush, or slightly behind lower ceiling surface.

## WET WALL:

Plaster flush up against lamphead opening.

Lamphead wall opening

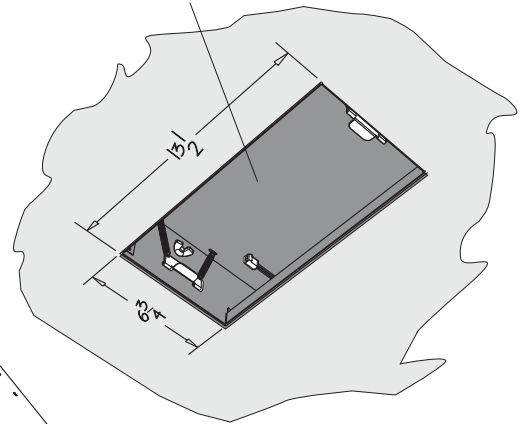

# WIRING INSTRUCTIONS

## DE-ENERGIZE BRANCH CIRCUIT AT BREAKER PANEL

Select and remove desired knockout(s) for AC power input with at least 12" of AC power leads extending into inside of backbox. Secure cable with approved wire clamp and make connections using wire nuts supplied. Connect wires per local codes. Connect to transformer as follows:

**BLACK** Lead for **120V** or **ORANGE** Lead for **277V** (CAP UNUSED LEAD) **WHITE** Lead for **Neutral**

Connect **GREEN/YELLOW** Lead for **GROUND**. Dress AC and Ground wires down to bottom of backbox.

**DO NOT REAPPLY POWER UNTIL FINAL SETUP**

## INSTALL BACK BOX SHELF

Feed transformer secondary cable (with connector) through hole in shelf and insert shelf into backbox with position of front and top indicated by label.

Dress transformer input leads to avoid interference with backbox shelf locking tabs.

Snap shelf into retaining slots in backbox by engaging lower latches, then rotate shelf to upper latches. See MAINTENANCE for instructions on removing backbox shelf.

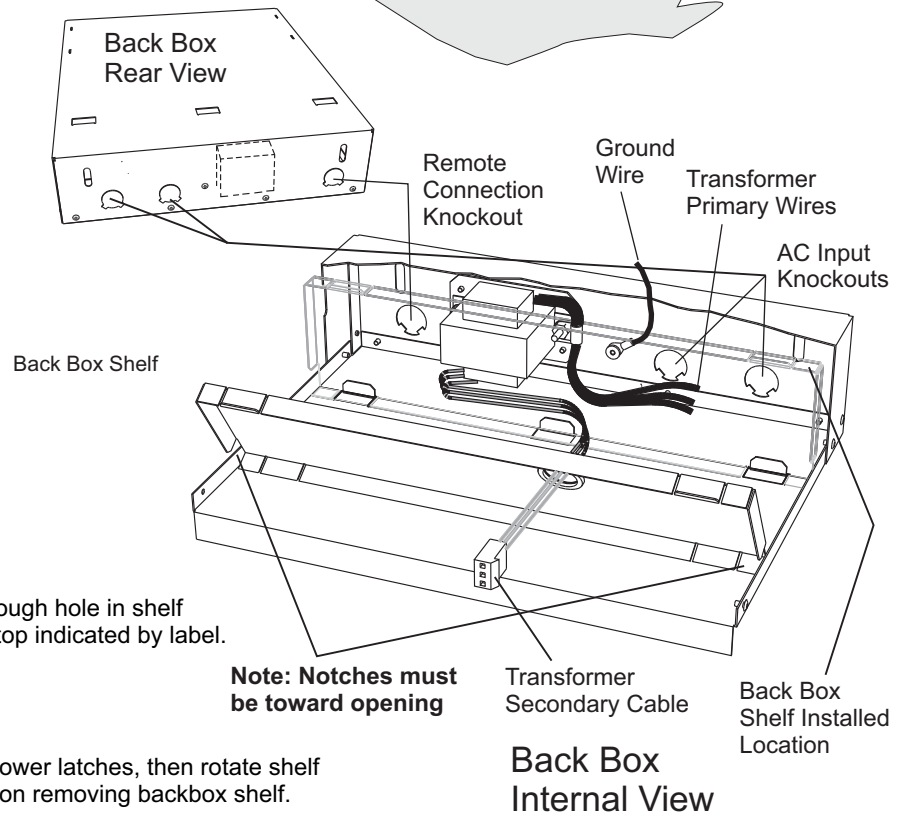

# BATTERY INSTALLATION

THIS PRODUCT IS SUPPLIED WITH A CHOICE OF 2 TYPES OF BATTERY SOURCES:  
SEALED LEAD CALCIUM (LC)  
NICKEL CADMIUM (Ni-Cd)

Depending on the product wattage and run-time ratings, there may be 1, 2 or 3 Batteries used.

Insert Battery(s) (**TERMINALS OR CONNECTORS FACING OUT**) through Lamphead opening. Allow Transformer Cable to extend out through Lamphead opening.

Battery(s) should be fully bottomed on Back Box Shelf.

Attach Battery Cable to Battery(s) ensuring that proper polarity is observed.

**NOTE:** Disconnected Battery must be recharged within 120 days.

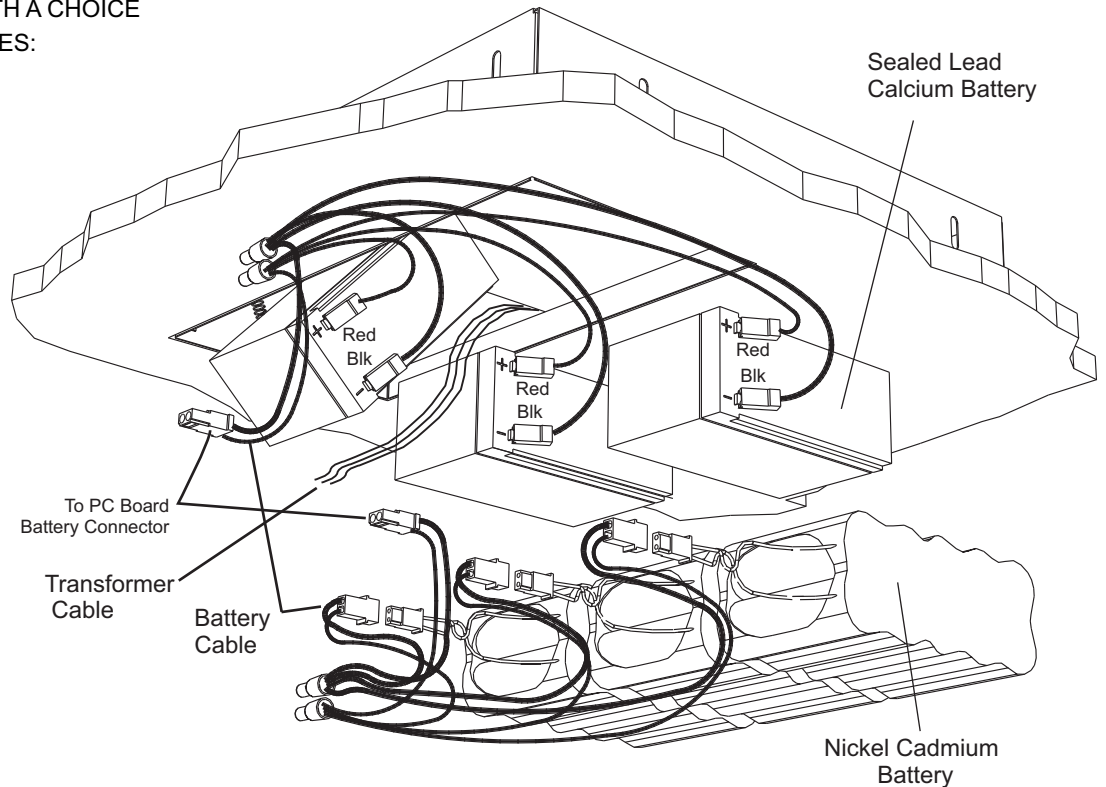

# LAMPHEAD INSTALLATION

Attach left side Lamphead Retaining Clip (viewed from Lamphead opening) into slots in Lamphead Frame, ensuring that Lamphead is oriented so company logo is closest to Battery. Allow right side of Lamphead to remain free for access to cable connections.

Connect 3 pin Transformer Cable and 2 pin Battery Cable to matching sockets on Printed Circuit Board.

**BATTERY CABLE, WITH BATTERIES CONNECTED, MUST BE ATTACHED BEFORE AC POWER IS APPLIED TO UNIT.**

**NOTE:** Once Battery is connected, unit must be energized within 30 days.

Access to retaining clip is through right side door.

Attach right side Lamphead Retaining clip into slots in Lamphead Frame. Door will spring back into place.

Door may be opened by pushing and holding the "TEST" button. "TEST" button must be held for 4 seconds (until the doors begin to open). The "TEST" button method is active only when AC power is not connected.

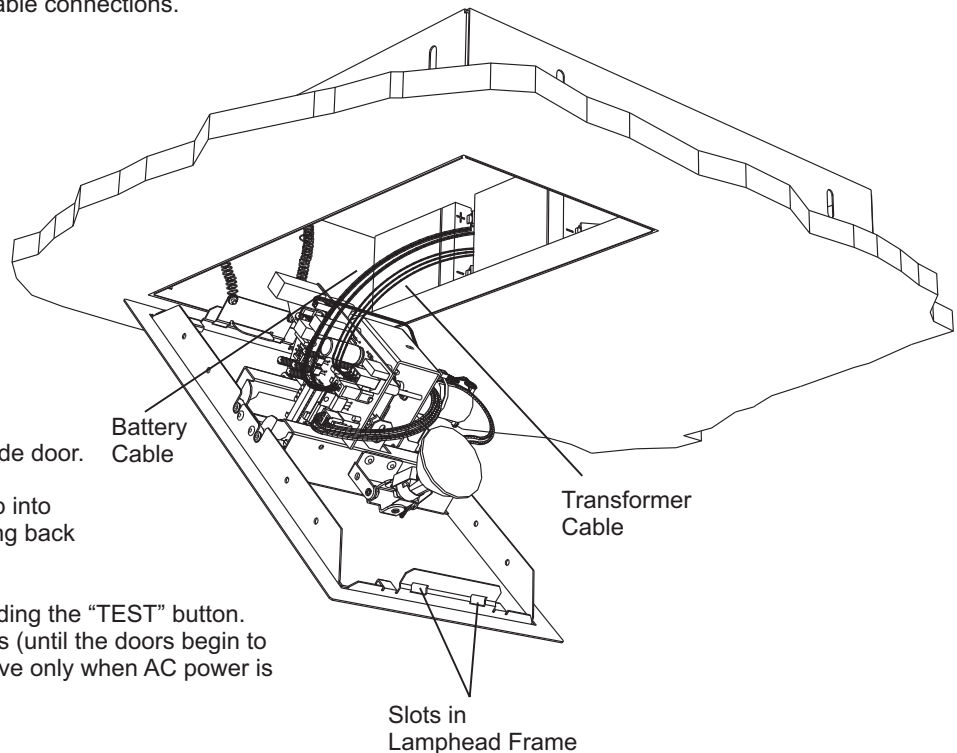

# ON-SITE PAINTING

The doors and frame have been factory painted. If a new finish is applied, extreme care should be taken that a seal is not formed between the door frame and doors, which may hinder the free operation of the door mechanism.

If the finish is sprayed on, we suggest that a thin cardboard or plastic strip be inserted between the doors and frame to prevent a paint seal. The indicator light, test switch and I.R. sensor should also be masked.

After the new finish is applied, a sharp edge such as a single edge razor or utility knife should be inserted in the opening between the doors and frame, and run around the doors to ensure no seal is formed.

Remove paint seal if new finish is applied

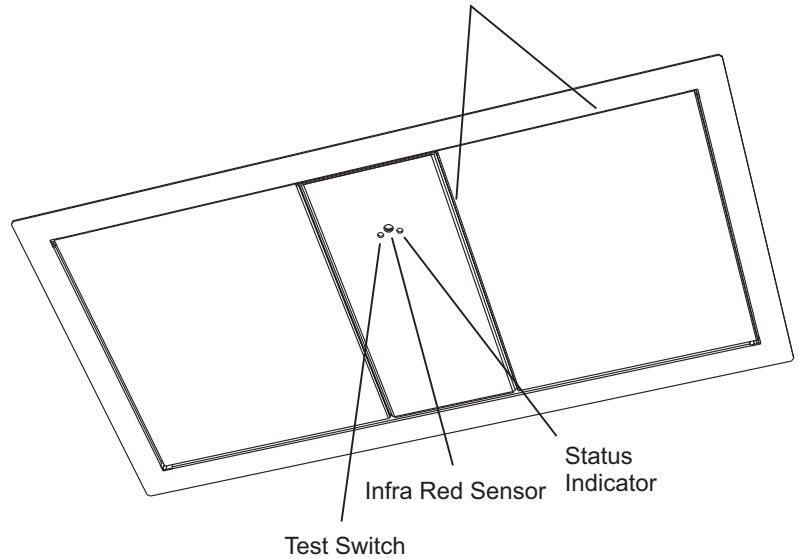

## SETUP AND OPERATION

### **REAPPLY POWER AND NOTIFY THE AUTHORITY HAVING JURISDICTION**

### **ALLOW BATTERIES TO CHARGE FOR AT LEAST 72 HOURS BEFORE OPERATING UNIT.**

#### **STATUS INDICATOR**

The "STATUS" indicator showing RED indicates that the Batteries are being charged. The indicator showing GREEN indicates fully charged Batteries.

#### **TEST SWITCH**

The "TEST SWITCH" is used to simulate failure of AC power. It can perform a USER test for 30 seconds or 90 minutes. By pushing the Switch for 1 second, the Doors will open and the Lamps will illuminate for 30 seconds. If the Switch is pushed for 4 seconds, and the "STATUS" indicator shows GREEN indicating fully charged Batteries, the Doors will open and the Lamps will illuminate for 90 minutes. If the Batteries are not fully charged, the 30 second test will run.

In either mode, the USER test can be cancelled by pushing the switch again.

#### **INFRA RED REMOTE TESTING**

The USER test can be performed up to 50 feet away, by using the "INFRA RED REMOTE TESTING TRANSMITTER". By aiming the TRANSMITTER at the SENSOR window and pushing either the "30 SECOND" or "90 MINUTE" button for 1 second, all the "TEST SWITCH" functions can be performed.

#### **RETRANSFER DELAY**

A 15 minute retransfer delay is available as a factory option. This option will keep the unit operating on battery backup for 15 minutes after power is restored. This feature allows HID lamps to warm up before the emergency lights are extinguished.

#### **FUSED REMOTE OUTPUT LEADS**

"FUSED REMOTE OUTPUT LEADS" can be installed as a factory option. These allow the use of remote 12 volt lampheads. The remote lamphead wattage added to the internal lamp wattage must not exceed the Output Load rating of the unit. Contractor will access leads through knockout in Backbox and make splice connections to leads.

#### **REMOTE INDICATOR DISPLAY**

For applications where it is undesirable to have the indicator on the Lamphead, a Remote Indicator Display is offered as a factory option. The indicator is mounted in a switchplate panel which can be mounted in a standard 2" Switch Box supplied by others. Interconnecting wires should be AWG 22 or larger with a maximum run of 100 feet. Suitable cable is UL Type CL2 Thermostat Cable. Wire colors must be matched for correct polarity.

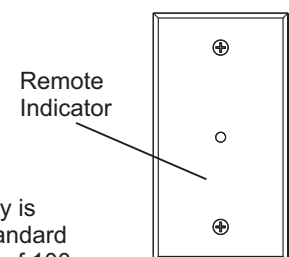

# LAMP ADJUSTMENT

Genie Fully Recessed Emergency Light has 2 adjustable lampholders mounted on the moveable doors. The lampholders have full aiming capability providing optimum lighting patterns.

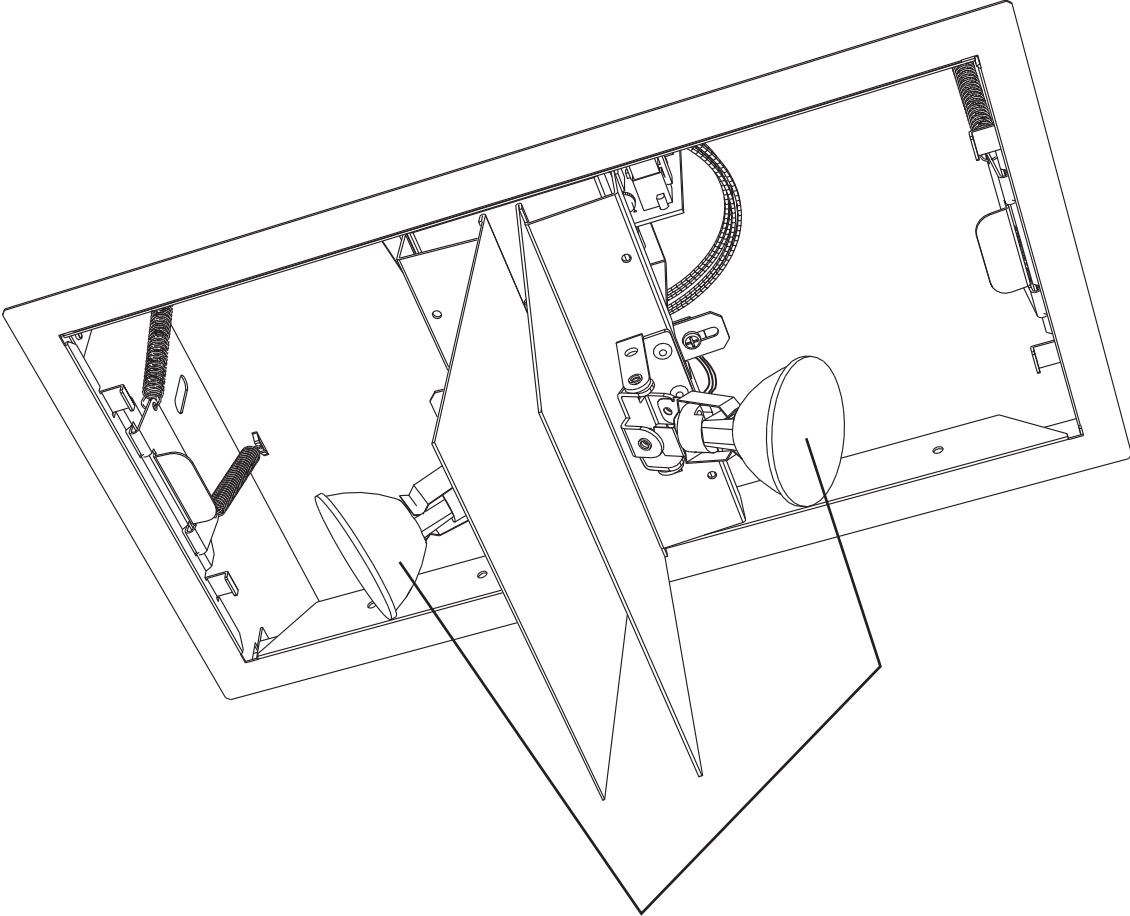

Adjustable Lampholder

# SELF-TESTING / SELF-DIAGNOSTIC

This unit meets the requirements of NFPA 101 for Periodic Testing of Emergency Lighting Equipment. It provides visual indication of unit malfunctions including:

- Battery Fault
- Charger Fault
- Transfer Fault
- Lamp Fault
- Door Fault

An automatic self-test and diagnostic function will be performed every 28 days. The doors will open for approximately 1 second and then close, without the lamps turning on. Following this, a load test will be performed for 29 minutes checking for a lamp, battery or transfer fault. This test will be performed only if the battery is fully charged. If not, the test will automatically reschedule. The charger function is monitored continuously.

A manual user test can be performed for 30 seconds or 90 minutes. By pushing the "TEST" Switch for 1 second, the Doors will open and the Lamps will illuminate for 30 seconds. If the Switch is pushed for 4 seconds, and the "STATUS" indicator shows GREEN indicating fully charged Batteries, the Doors will open and the Lamps will illuminate for 90 minutes. If the Batteries are not fully charged, the 30 second test will run.

In either mode, the user test can be cancelled by pushing and holding the "TEST" Switch for 1 second after the lamps come on.

The manual user tests can also be initiated by the INFRA RED REMOTE TESTING TRANSMITTER.

<b>STATUS DISPLAY SIGNALS</b>	<b>FUNCTION</b>	<b>ACTION</b>
Continuous Green	Battery in Float/Trickle Charge	None
Continuous Red	Battery High Charging	Wait for Green Status
Flashing Green	In Test Mode	Wait for Test to Complete
Alternate Red and Green	Insufficient Charge for User Test	Wait for Full Charge
Red - One Blink ON / Pause	Transfer System Failure	Factory Service
Red - Two Blinks ON / Pause	Battery Failure	Check Connections / Replace Battery
Red - Three Blinks ON / Pause	Charger Failure	Factory Service
Red - Four Blinks ON / Pause	Door Failure	Check for Paint Seal
Red - Five Blinks ON / Pause	Lamp Failure	Replace Lamp

# **MAINTENANCE**

## **REMOVAL OF BACKBOX SHELF**

Backbox shelf can be removed from backbox by pressing in 2 locking tabs on either the front or rear face of backbox and sliding shelf toward lamphead opening.

Locking tabs can be released from inside backbox using a flat blade screwdriver.

Press in locking tabs to remove shelf

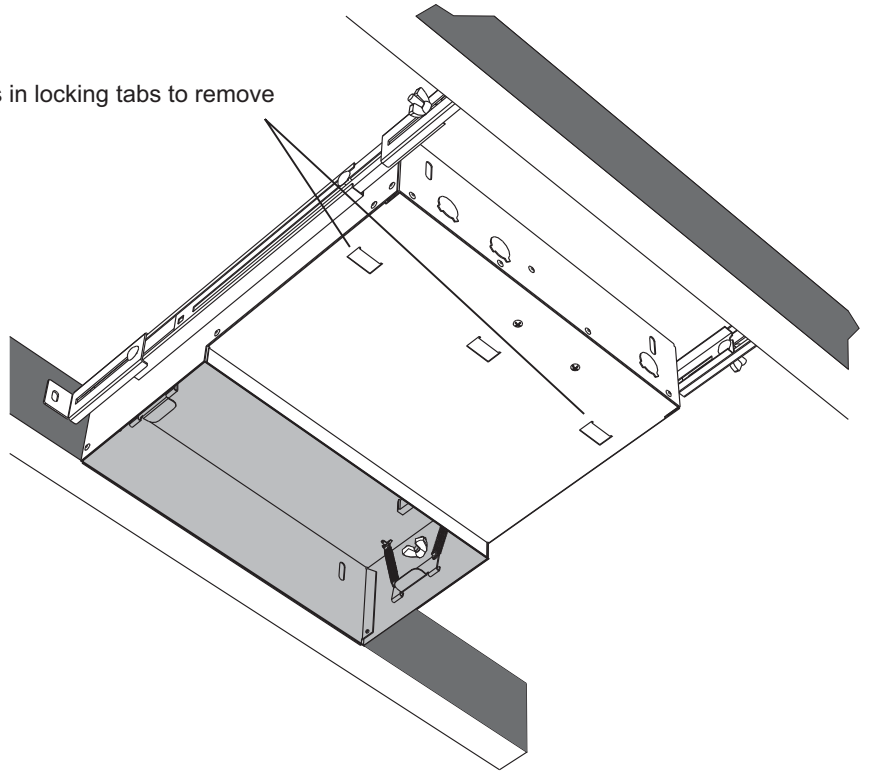

## **LAMP REPLACEMENT**

Before replacing lamps, disconnect power at breaker panel. Push and hold "TEST" switch for 4 seconds extinguishing lamps. Grasp socket so aiming position is not disturbed. Be sure replacement lamp is totally seated in socket. Refer to replacement lamp part number. Use only specified replacement lamps.

The self-diagnostic system "learns" the lamp wattage when the unit is initially powered. It is therefore necessary to replace the lamps with the same wattage as was initially "learned", or else the system will report a defective lamp. If it becomes necessary to change the lamp wattage, within the ratings of the unit; this can be accomplished by disconnecting power at the breaker panel and unplugging the Battery Cable. When power at the breaker panel is reconnected and the Battery Cable is replugged, the system will "learn" the new lamp wattage.

## **BATTERY**

The battery supplied in this unit requires no maintenance. However, it should be periodically tested (see TEST) and replaced whenever it will no longer operate the emergency lamps for the durations specified. Replace using the BATTERY INSTALLATION procedure. Refer to replacement battery part number. Use only specified replacement batteries.

Used batteries may not be disposed of in the municipal solid waste stream. Arrangements for recycling Sealed Lead Calcium batteries can be made at 1-323-278-1900. For information on local recycling drop off points for Nickel Cadmium batteries, call 1-800-BATTERY.