

Contractors Guide
Emergency Lighting Central Inverter for System
Step By Step Procedures
8,000 thru 12,500 Watt/VA (Single Phase)
Installation Guidelines

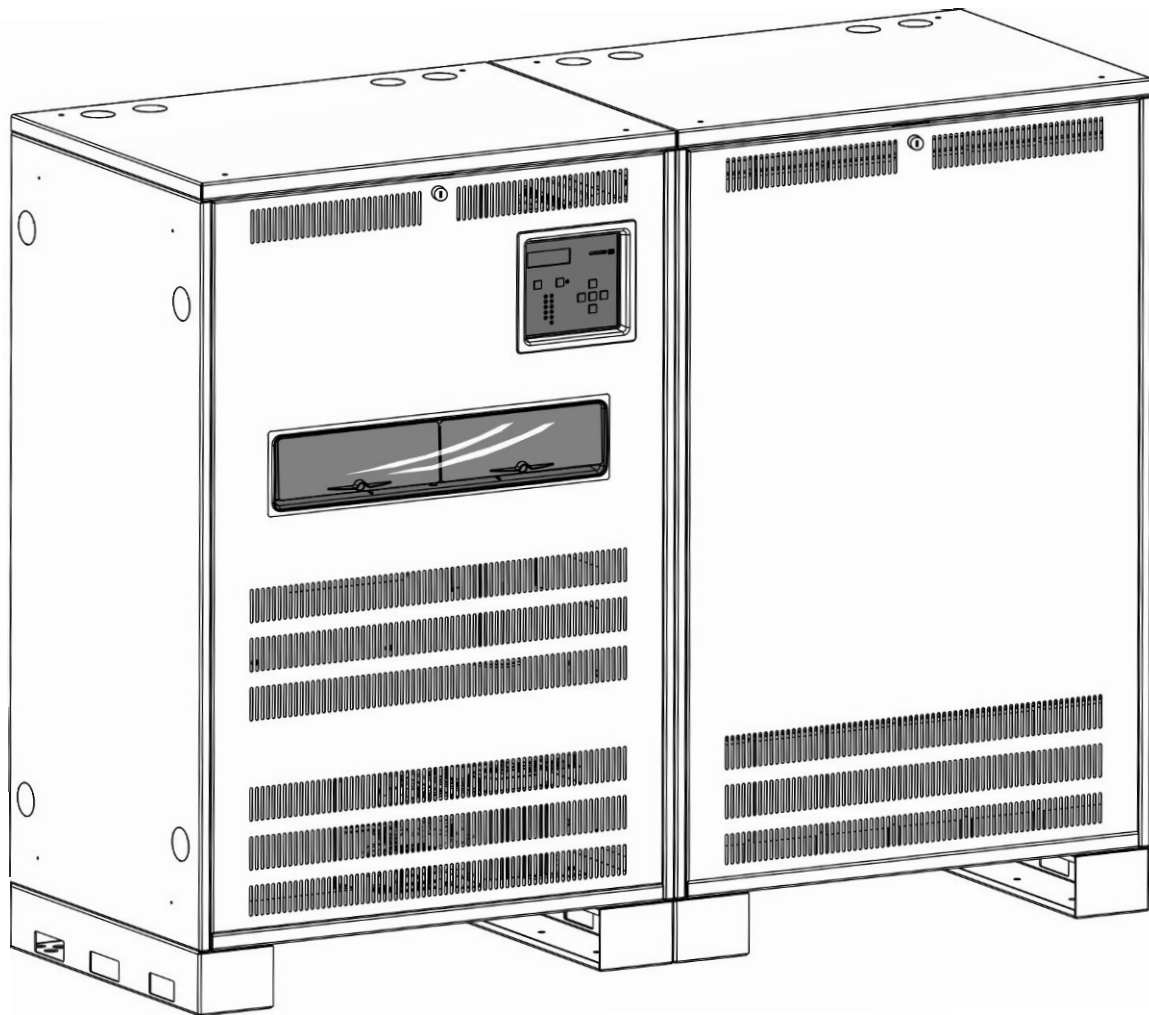

5 Step Installation

1. Mounting the Cabinet
2. Install / Connect Batteries
3. Install Conduit
4. Install AC Wiring
5. Energize System

For additional information, please refer to the Installation/Operation Manual

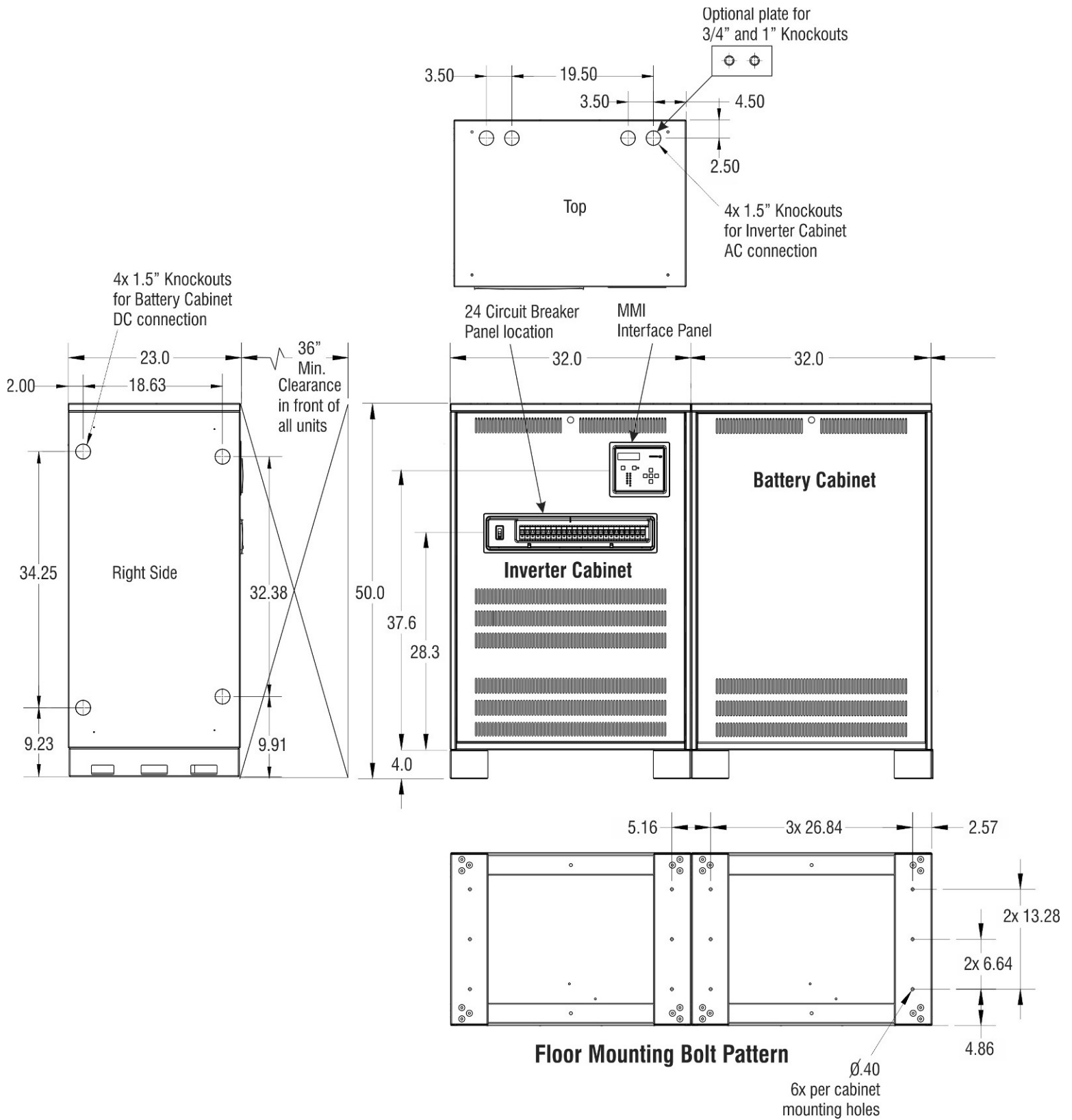

Overall Mounting Dimensions and Knockout Locations

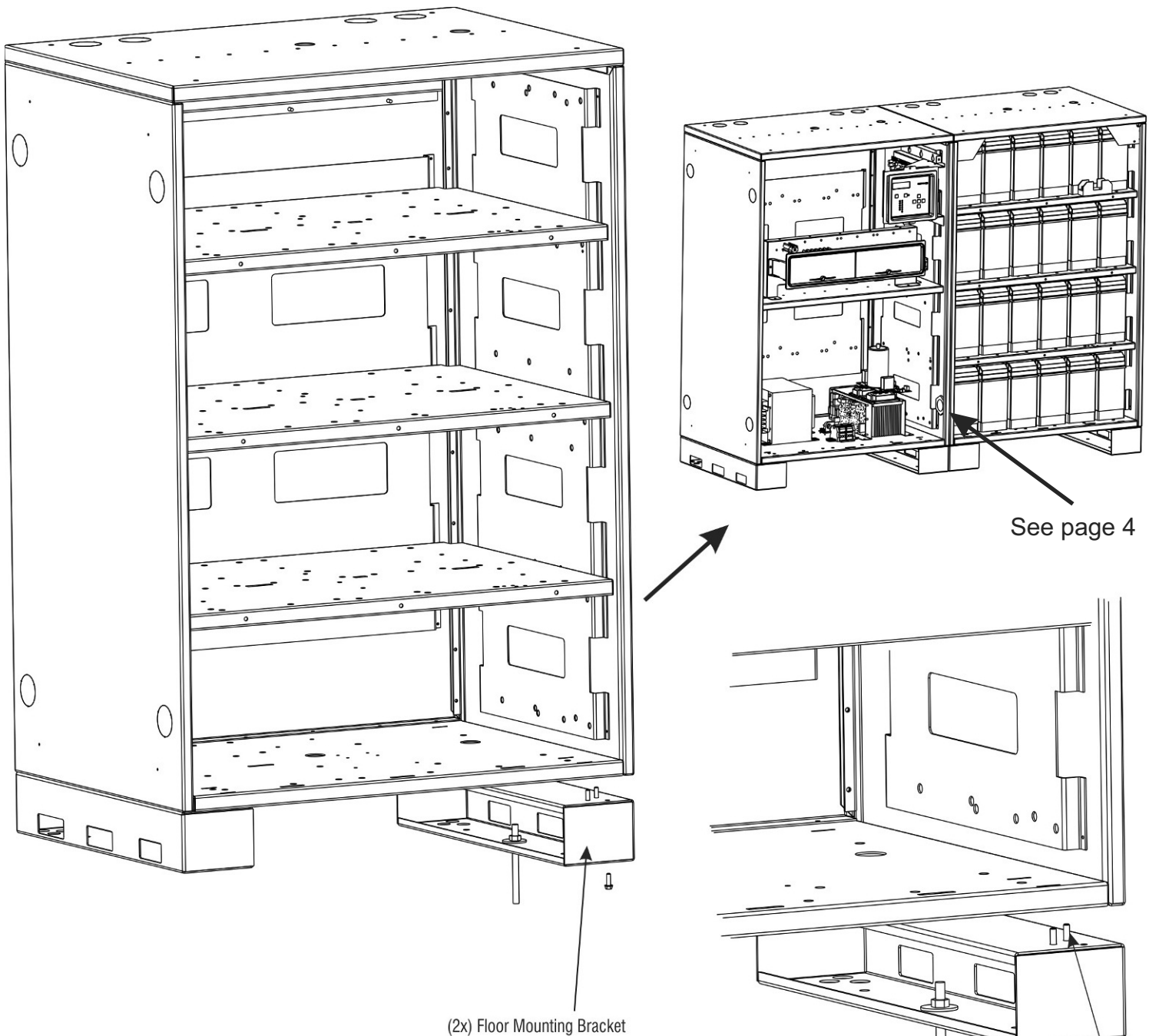

Step 1

Mounting the Cabinets

Prepare floor so that it is level and smooth and secure Inverter and Battery Cabinet into floor using Concrete Wedge Anchors or other suitable method (hardware provided by others).

Note - Uneven surfaces may cause difficult front cover removal/installation

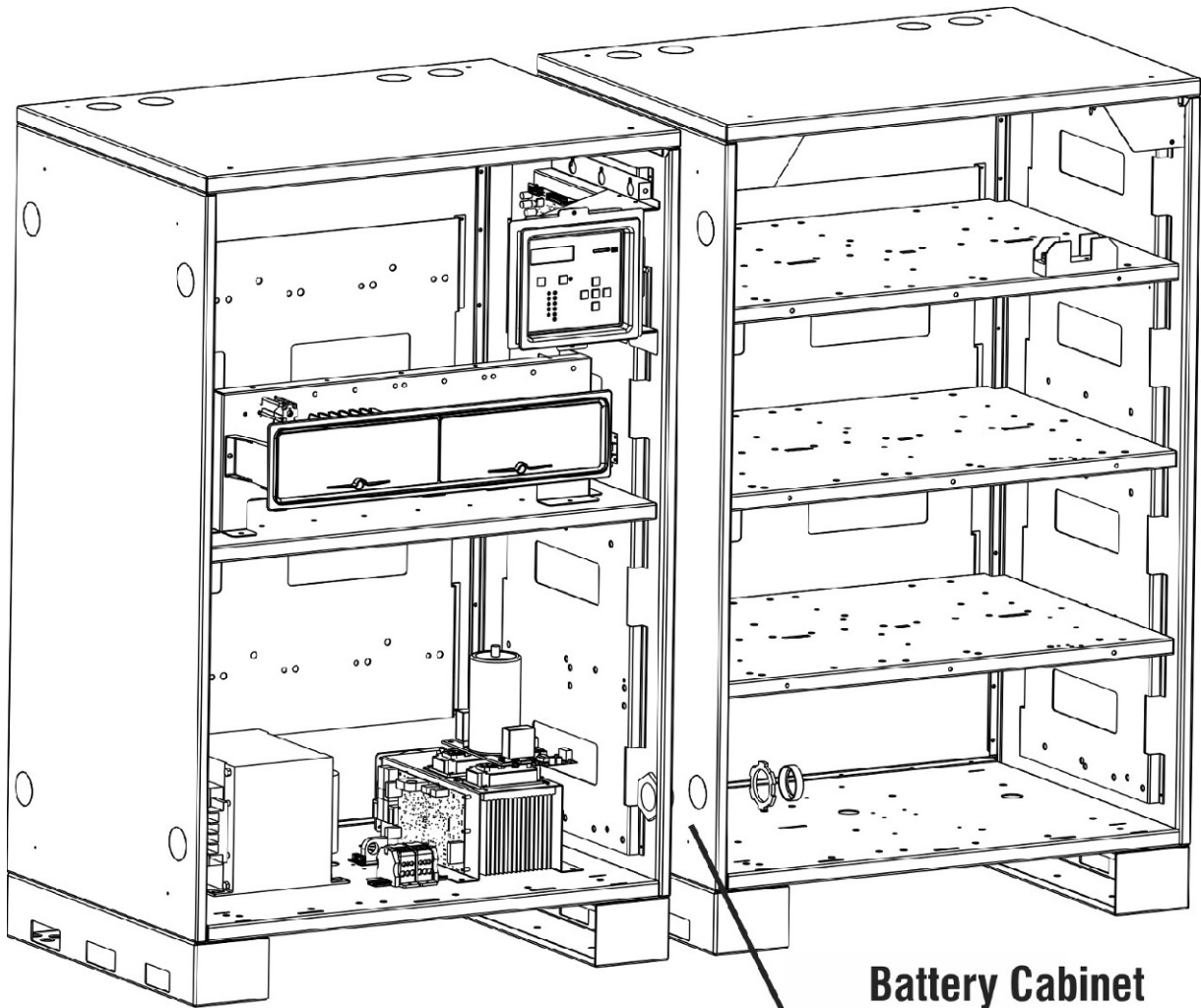

Master Inverter Cabinet

Battery Cabinet

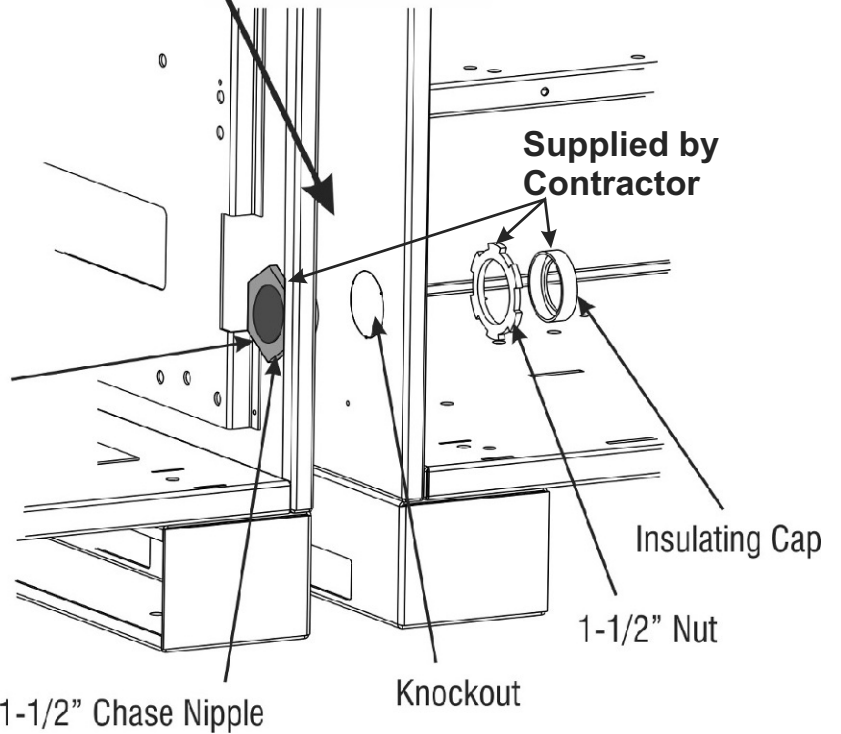

Battery Wire Port

Supplied by Contractor

Insulating Cap

1-1/2" Nut

Knockout

1-1/2" Chase Nipple

Step 1 - Continued
Connecting the Cabinets

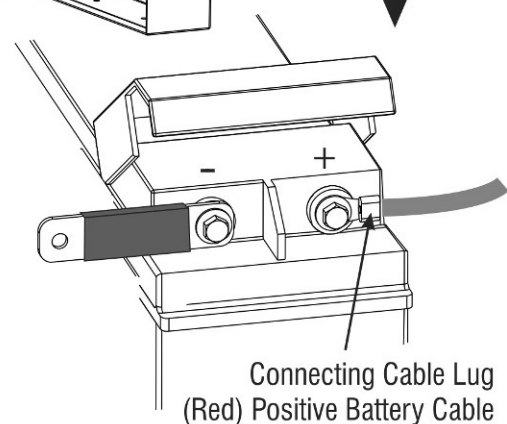
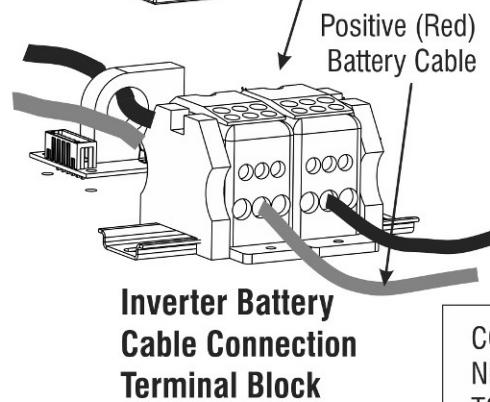
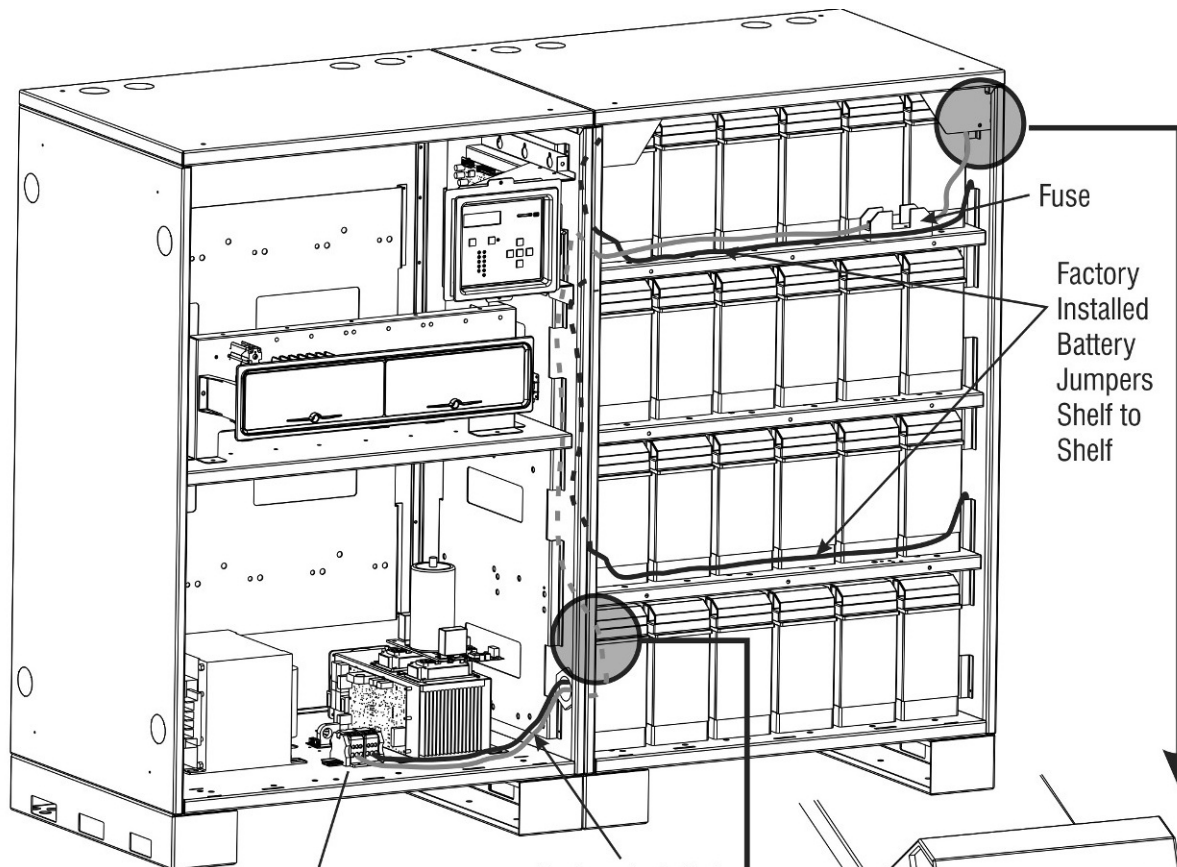

CONNECT
NEGATIVE CABLE
TO BATTERY
AFTER ALL
BATTERY
CONNECTIONS
ARE MADE

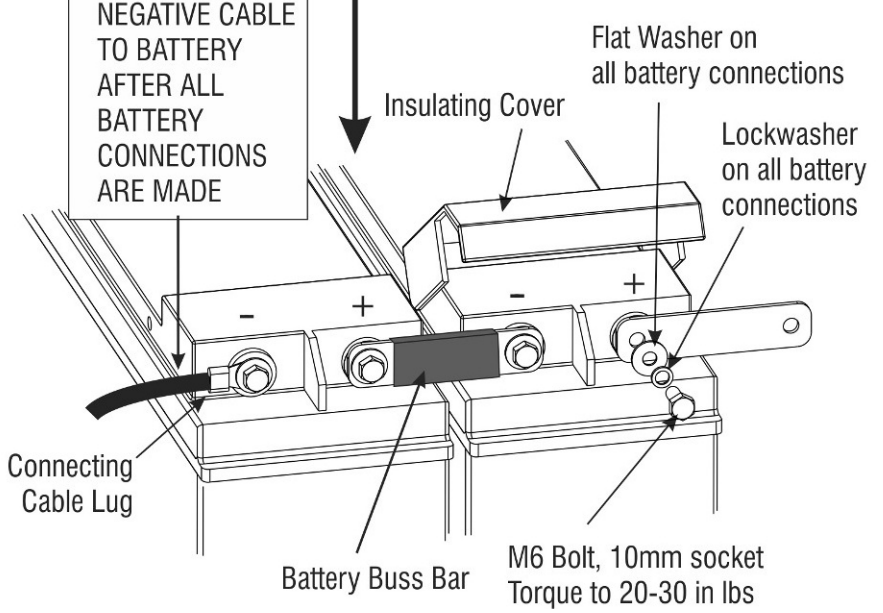

Nominal DC Voltage
192VDC (16 Batteries)
240VDC (20 Batteries)
288VDC (24 Batteries)
See Detailed Diagram
on Cabinet Door

Step 2 Installing and Wiring the Batteries

Note – Always ensure that the DC Fuse is removed before starting installation.

Battery positive and negative are wired into the Inverter Battery Cable Connection Terminal Block

1. Load all batteries onto the battery shelves. Ensure proper spacing between batteries so that Battery-Battery Buss Bar Jumpers can be installed properly.
2. Connect Jumper Battery Cables from lower right battery (+) to upper left battery (-).
3. Connect Battery String Positive (upper right battery +) to Fuse (Red Wire)
4. Connect all Battery Buss Bars between adjacent batteries
5. Connect Battery String Negative (lower left battery -)
6. Measure and ensure correct DC string voltage and ensure all connections are made.
7. Install Fuse

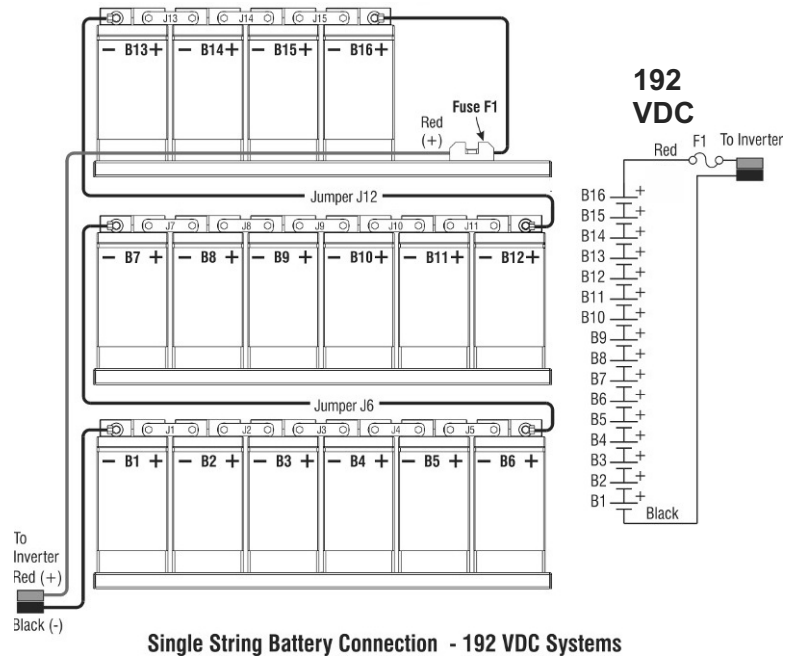

Single String Battery Connection - 192 VDC Systems

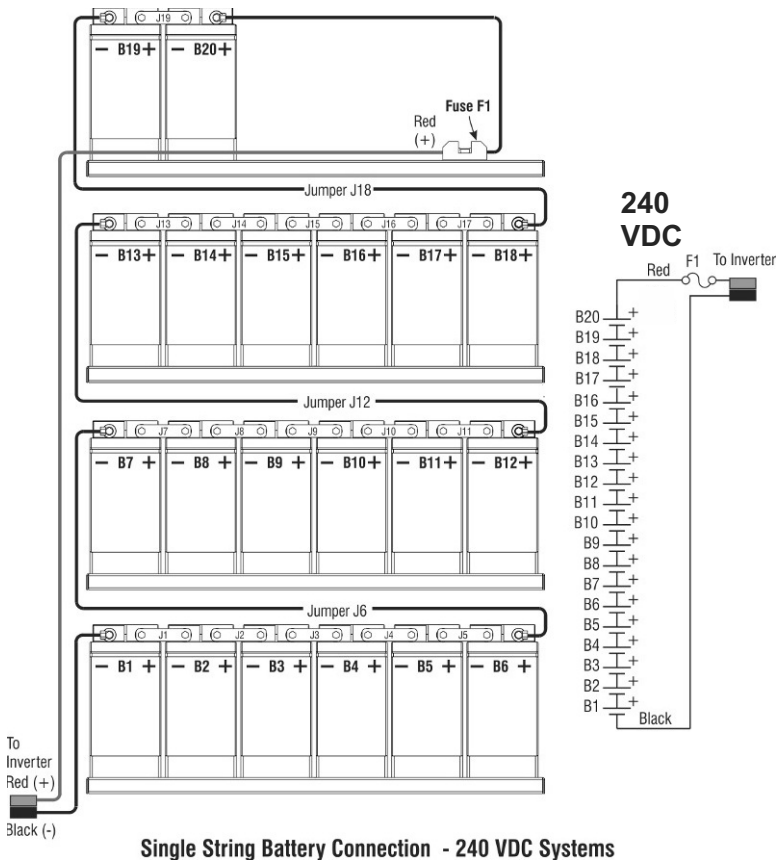

Single String Battery Connection - 240 VDC Systems

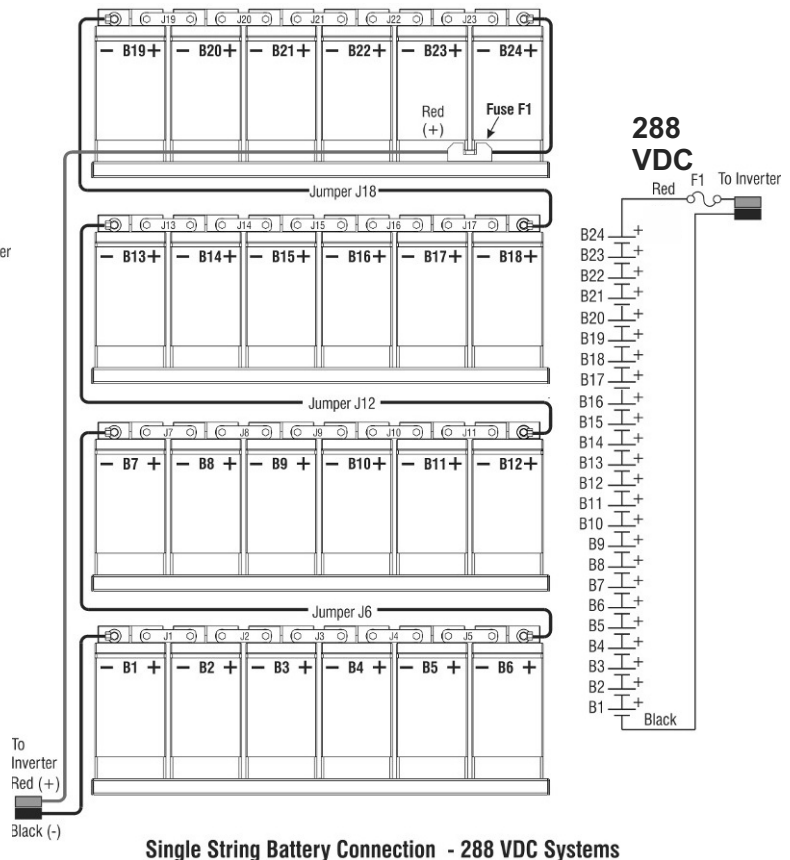

Single String Battery Connection - 288 VDC Systems

Step 3

Installing the AC Conduit

See Illustration on page 2

Use Provided Knock-Outs located on Tops and Sides of Inverter Cabinet Note – Drilling into cabinets may VOID warranty - metal shavings can short circuit electronic components.

Input and Output Wires should be run in separate conduit per NEC.
Knock-Outs are 1-1/2" with optional dual size for 7/8" and 1-1/8."

Follow all Local and National Electrical Codes (NEC)

Step 4

Installing the AC Wiring

See illustration on page 8

Ensure the AC Input Breaker CB1 is in the OFF (Down) position before starting. See Installation/Operating manual (section 7) for AC Input and Output AC ratings.

Remove Plastic AC Circuit Breaker Cover (secured with 2 x 1/4-20 bolts).

Wire AC input directly to top side of Input Breaker - AC Input Circuit Breaker on Left side.

Wire Input Neutral and Ground connections to appropriate Neutral and Ground Bars.

Do not share Neutrals with Emergency and Non- Emergency loads.

Connect AC output wires to the top side of Normally-On terminal block or output circuit breakers if provided. Standard equipment always has a Normally-On output terminal block for output wire connections.

AC Output Breakers are Optional. Follow all Local and National Electrical Codes (NEC).

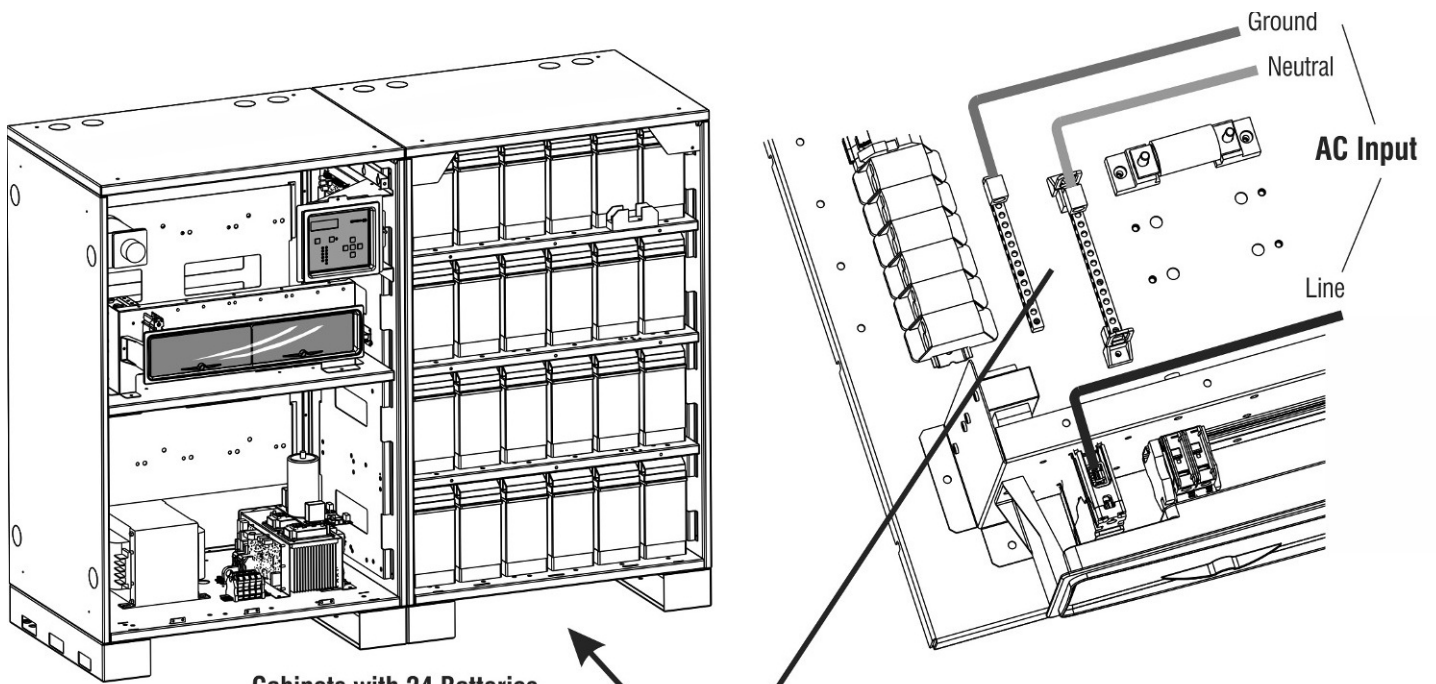

**Cabinets with 24 Batteries
288 VDC System**

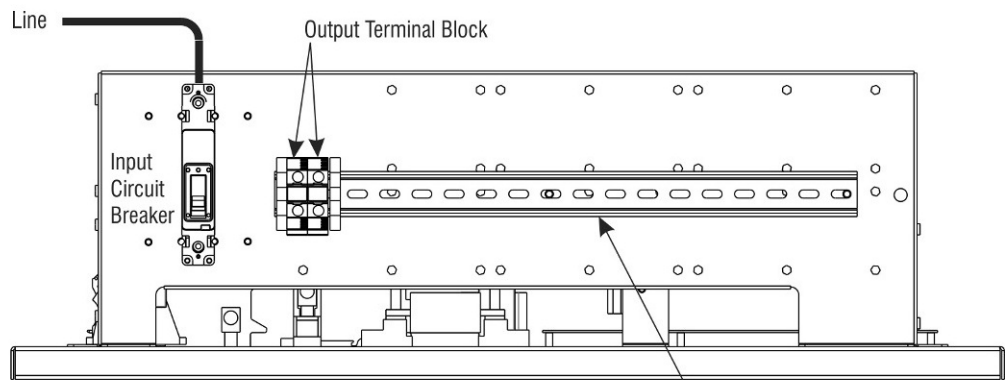
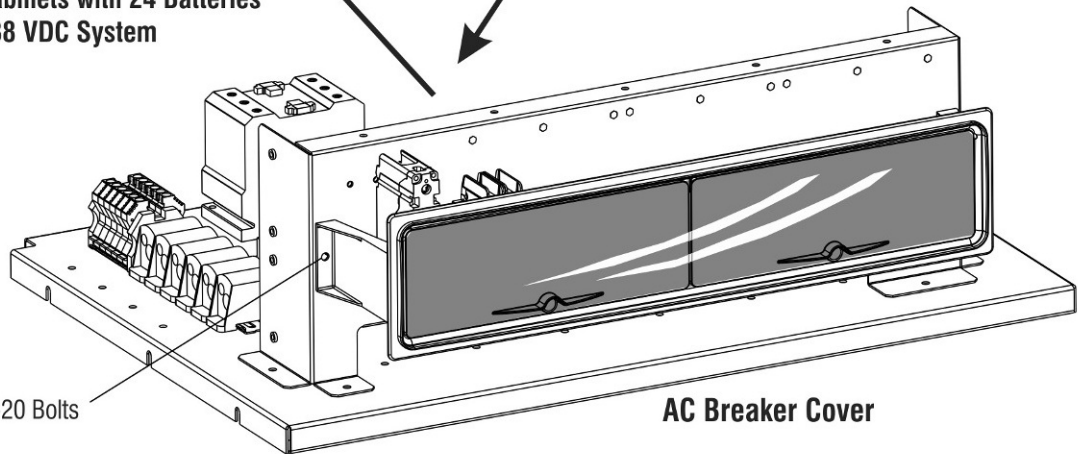

Standard Breaker Panel

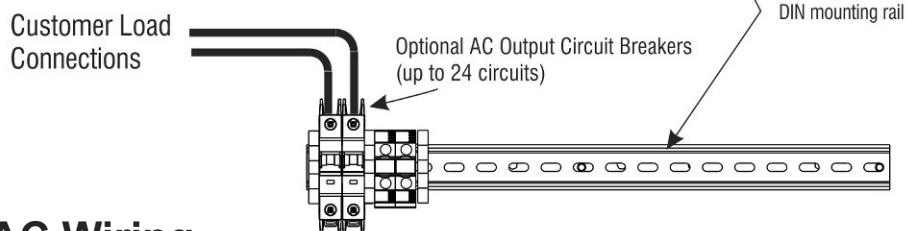

Optional AC Output Breakers and Terminal Blocks

Installing the AC Wiring

Step 5

Starting Up/Energizing the Unit

Ensure batteries are installed, the wiring is checked per Step 2. Ensure AC Power is present and lighting loads are connected per Step 4.

Flip on Input Circuit Breaker CB1.

Flip on System's On/Off Switch located to the right of the Interface Panel. System will go through start up diagnostics and go into charge mode if there are no errors. Press the system test button or momentarily drop AC power to energize emergency power and ensure that the inverter can support the lighting loads without going into a fault condition.

Replace and secure AC Breaker Cover and its clear access window with locking screw. Install front cover to Cabinets.

Contents of Shipment 8KW to 12.5KW Models include:

Cabinet Floor Mounting Brackets – Attached to Cabinets.

Batteries – 16 pcs for 8KW, 20 pcs for 10.5KW, 24 pcs for 12.5KW

Battery Cable Kit – All Models

Installation/Operation Manual – All Models

Tools Required for Installation

(Typical all models)

3/8" Nut Driver and/or 3/8" Socket and Ratchet

Straight Blade Screwdriver(s)

Square Head (Robertson) Screw driver

Phillips Head Screwdriver

10MM Socket and Ratchet – or – 10MM Wrench (Torque set to 30 in-lbs.)

3/16 Allen Head (Only for Side By Side mounting – Battery Cable Replacement)

Hardware for securing cabinet to floor – i.e. Hilti Kwik Bolt or equivalent

Multi-Meter capable of DC and AC Measurements