



# E3U

Micro Inverter

DATE:

PROJECT

COMMENTS:

## FEATURES

- Capable of powering LED, fluorescent, or incandescent fixtures.
- Utilizes true sinusoidal AC pulse width modulated (PWM) design to provide clean 60 Hz emergency output.
- Universal 120/277VAC, 50/60Hz input/output.
- Auto Preset Dimming (0-10V) enables adjustment of connected loads up to 360W for E3U-36 and 900W for E3U-100.
- Output voltage is automatically adjusted based on different input voltages.
- Self-Test/Diagnostic standard.
- Startup Test/Diagnostic standard.
- Preprogrammed scheduled self-tests occur 24 hours and up to 7 days after initial power-on, with monthly tests every 30 days and annual tests every 52 weeks.
- Supports Normally-On, Normally-Off, or Switched outputs.
- Remote mounting distance of up to 1,000 feet.
- Over voltage, over current, inrush current limiting, over temperature, short circuit, and open circuit protection
- Suitable for indoor, dry, and damp locations.

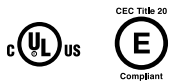

CLICK THE IMAGE TO VIEW ALTERNATE PRODUCT PHOTOS  
Only available with Adobe Acrobat and Acrobat Reader

## ORDERING INFORMATION E3U-36

### 1. SERIES

E3U

### 2. VA RATING

36 36W  
100 100W

## SPECIFICATIONS

### CONSTRUCTION

- Aluminum housing

### INPUT VOLTAGE

- 120/277VAC, 50/60Hz

### OUTPUT

- Lamp Type: LED, fluorescent, or incandescent bulbs
- Voltage: 120/277VAC, 50/60Hz
- Efficiency Rating:
  - 80% (E3U-36)
  - 84% (E3U-100)
- Rated Current:
  - 0.1A (E3U-36)
  - 0.48A at 120V (E3U-100)
- Rated Power:
  - 7W (E3U-36)
  - 35W (E3U-100)
- Power Factor: 0.5-0.9 leading, 0.5-0.9 lagging
- Output Voltage: 120/277VAC, 50/60Hz

### Output Power:

- 36W (E3U-36)
- 100W (E3U-100)

### Maximum Pass Through:

- 360W (E3U-36)
- 900W (E3U-100)

### BATTERY

- Lithium Cobalt (LiCoO2)
- Recharge Time:
  - 24 hours (E3U-36)
  - 12 hours (E3U-100)
- Discharge Time: 90 minutes
- Charging Current:
  - 0.34A Max (E3U-36)
  - 0.6A Max (E3U-100)
- Protections: Over voltage, over current, Inrush current limiting, over temperature, short circuit, open circuit

### TEMPERATURE RATING

- From 0° to 50°C (32° to 122°F)

### APPROVALS

- UL 924
- NFPA101 Life Safety Code
- NFPA 70 National Electrical Code
- OSHA
- CEC Title 20 Compliant

### WARRANTY

- Isolite offers a 5-year limited warranty. For further details, refer to General Warranty and Obligations in the Isolite manual or on our website. Lamps not warranted

**DIMENSIONS**

**E3U-36**

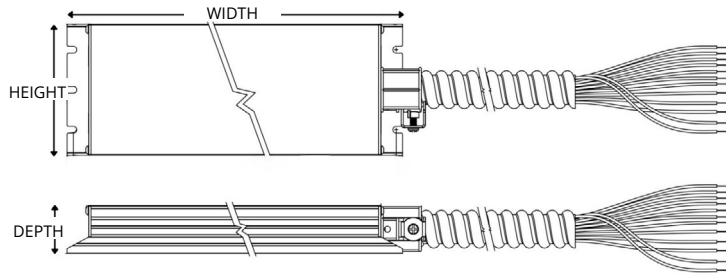

**E3U-100**

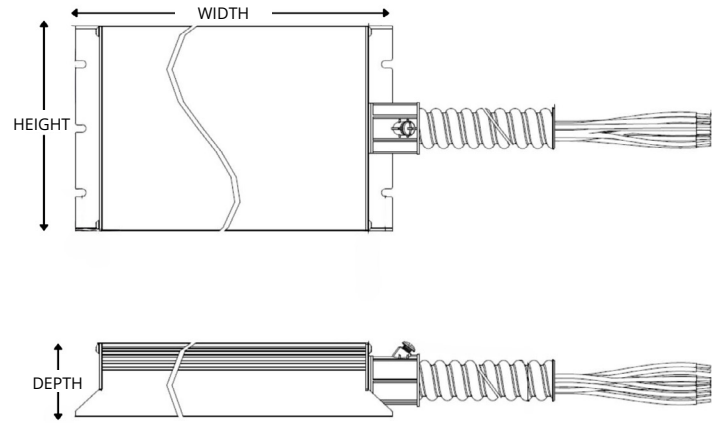

MODEL #	LENGTH	WIDTH	HEIGHT	MOUNTING CENTER
E3U-36	13.54"	3.23"	1.18"	13.31"
E3U-100	13.63"	4.53"	1.63"	13.31"